

Western Pen Kit

Kit Features:

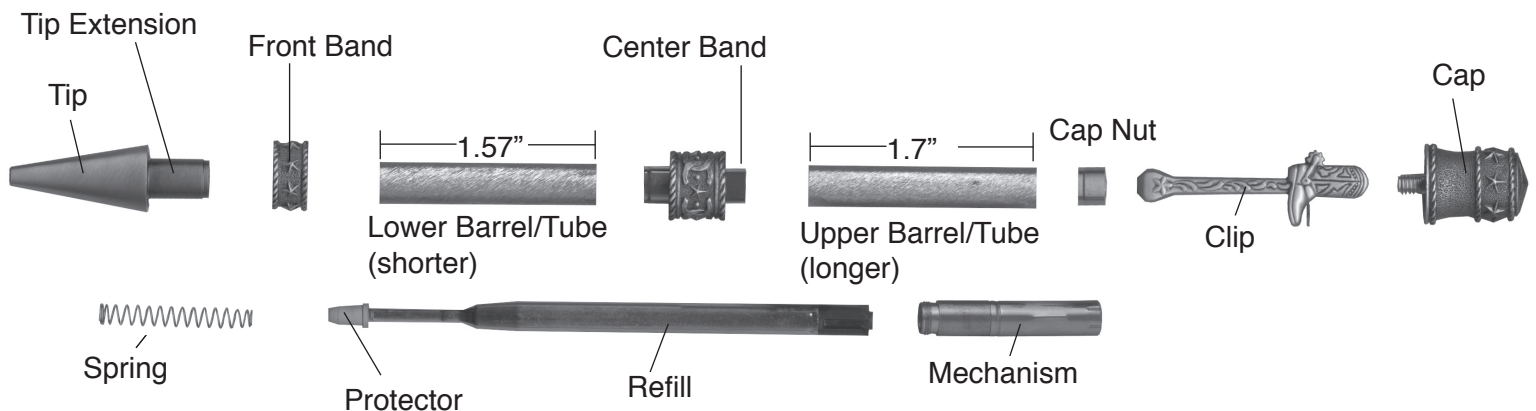
- Easy to turn with straight tubes
- Minimum parts - easy to assemble
- Available in multiple finishes
- Attractive cast and etched themed components
- Uses Parker® Style Refills
- Overall Length: 5-5/8"

Required Accessories:

- 7mm Pen Mandrel
- Drill Bit: 8mm #PKPARK-8MM
- Bushing set(3 pc): #PKWESTBU
- Barrel Trimming set: #PKTRIM8
- Live Tailstock Center
- 2 Part Epoxy Glue or Insta Cure (Cyanoacrylate) Glue
- Pen Blank: Minimum Size - 3/4" x 3-1/2" LONG

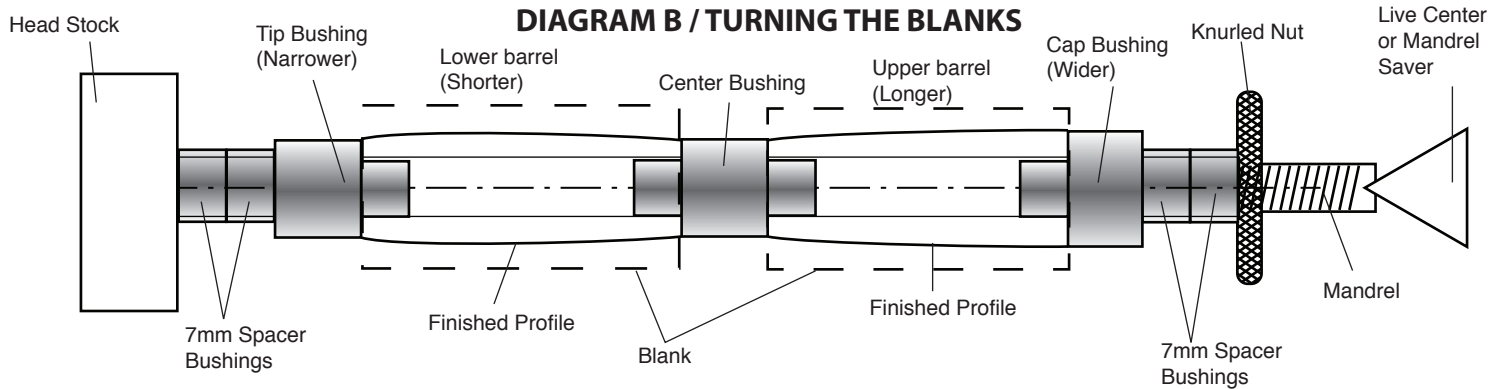


DIAGRAM A / PARTS LAYOUT



Preparing the Blank:

- Cut 2 blanks to the length of the tubes and add 1/16" for squaring off.
- Drill 8mm holes lengthwise through the blanks.
- Spread glue over the tube(s), insert the blank with a twisting motion to spread the glue evenly inside.
- Center the tubes lengthwise inside the blanks.
- When the glue is dry, square the ends of the blanks. Use a 8mm barrel trimmer, or a universal pen blank squaring jig with a power disc sander. Take the excess material down flush with the ends of the brass tube. (do not trim beyond the length of the tube since this may interfere with operation of the mechanism and assembly). Use a barrel trimmer to clean the inside of the tube.



Turning the Blank

- Mount the bushings and blanks according to diagram B.
 - Thread on the knurled nut and hand tighten to hold all components in place.
 - Slide the tailstock up snugly against the mandrel shaft inserting the live center point into the mandrel dimple, lock in place.
 - Hand tighten the quill adjustment to firm up the mandrel. (DO NOT overtighten, it could damage the mandrel.
 - Using sharp tools, turn the blank down close to the bushing diameter. Turn the barrel (straight or to a profile of your choice)
 - Sand the blank down to be flush with the bushings gradually increasing the sandpaper grits.
 - Finish the barrel with your choice of polish. Allow sufficient time for the polish to cure.
- Refer to polish instructions.

Assembly

- Layout parts according to diagram A
- Affix the front band over the tip extension. Press this assembly into either end of the lower barrel (shorter).
- Press the non threaded end of the center band extension into the opposite end of the lower barrel.
- Affix the spring over the refill end and drop into the opening at the thread. Screw on the mechanism over the exposed center band threads.
- Press the cap nut, recess end in first into wider end of the upper barrel (longer.)
- Slide the clip washer over the thread on the cap. Screw this assembly into the cap nut in the upper barrel.
- Slide the upper barrel assembly over the mechanism, press together to close the gap.
- The pen operates by twisting the ends to advance or retract the refill.
- To replace the refill, unscrew the upper barrel to expose the refill.

Diagram C / Bushings #PKWESTBU

