

The Apex SE Click Pen Kit

PKVPEN • PKVPEN24 • PKVPENCH • PKVPENGM

Kit Features:

- Unique turned plunger design
- Suitable for many stylish profile variations
- Available in multiple finishes
- Hefty / Comfortable Pen

Required Accessories:

- 7mm Pen Mandrel
- Drill Bit: 8mm #PKPARK-8MM
- #PKVPENBU Bushing set(4 pc)
- #PKTRIMKIT Barrel Trimming set (USE 8MM SHAFT)
- Live Tailstock Center
- 2 Part Epoxy Glue or Insta Cure (Cyanoacrylate) Glue
- Pen Blank: Minimum Size - 3/4" X 3-3/4" L
- Plunger: 1/2" sq X 5/8" L



DIAGRAM A / PARTS LAYOUT

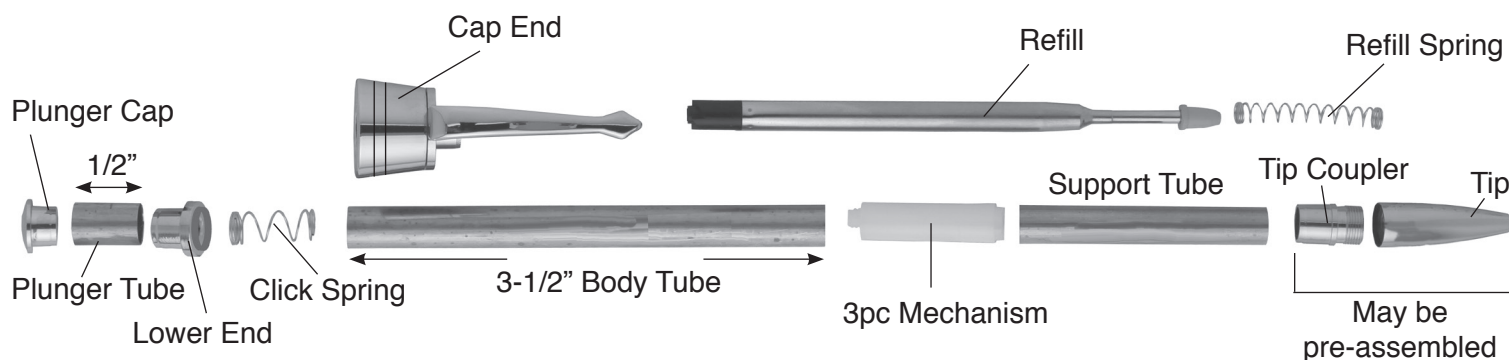

Preparing the Plunger Blank:

- Cut 1 blank to the length of the tube and add 1/16" for squaring off.
- Drill an 8mm hole lengthwise through the blank.
- Spread glue over the tube, insert the tube into the blank with a twisting motion to spread the glue evenly inside.
- Center the tube lengthwise inside the blank.
- When the glue is dry, square the ends of the blank. use a 8mm barrel trimmer with sleeve. Take the excess material down flush with the ends of the brass tube.

NOTE: Plunger bushings are not the same diameter. To insure smooth plunger operation. Do not exceed the wood over the bushings. Follow assembly instructions for positioning.

Preparing the Pen Body Blank:

- Cut 1 blank to the length of the tube and add 1/16" for squaring off.
 - Drill an 8mm hole lengthwise through the blank.
 - Spread glue over the tube, insert the tube into the blank with a twisting motion to spread the glue evenly inside.
 - Center the tube lengthwise inside the blank.
 - When the glue is dry, square the ends of the blank. You can use a 8mm barrel trimmer. Take the excess material down flush with the ends of the brass tube.
- NOTE:** The profile of the barrel is tapered. It is thin at the tip end. Do not taper to the tip. Shape the end for a wider diameter. See suggested profile in diagram B.

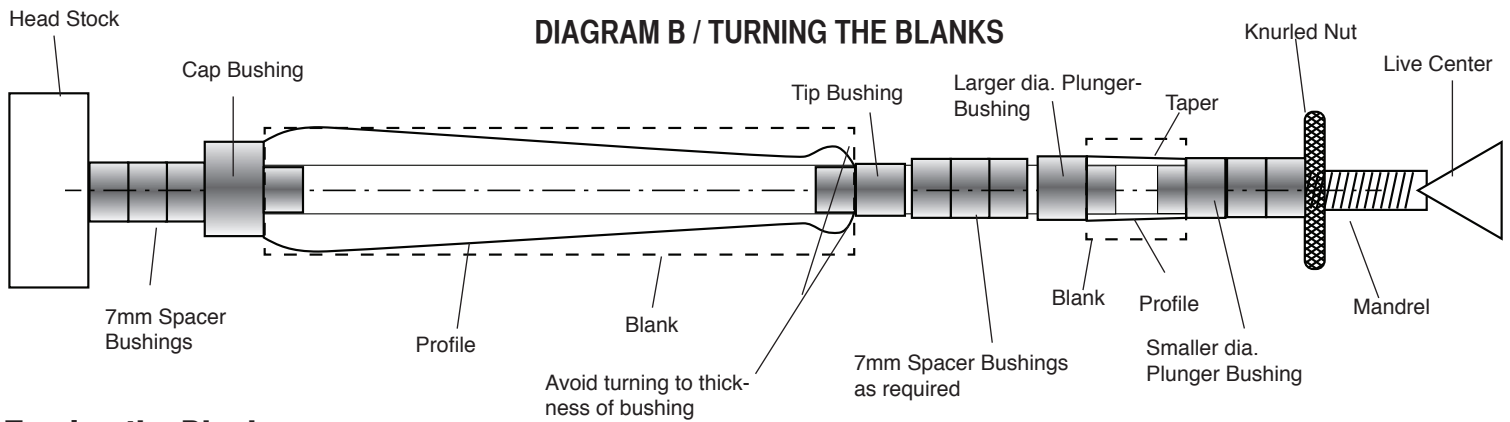

Turning the Blank

- You may turn the pen blank and the plunger on the same mandrel together.

Pen Blank: Turn the barrel to a pleasing profile. You may design a oversized bead on top and curve the wood at the tip to avoid the thin wall if turned straight to the bushing.

Plunger: 2 bushings are of different diameters. The wide bushing is also larger in diameter. Turn a straight profile

NOTE: Do not leave wood on the plunger to exceed the bushings otherwise it will effect the plunging and sliding. Sand smooth up to the bushings.

Assembly

- Layout parts according to diagram A

PEN BARREL:

- Insert the mechanism assembly, threaded end in first through the narrow end of the barrel.
- Follow with the support tube into the same opening.
- Screw the tip into the tip coupler (may be pre-assembled). Press the assembly into the same opening until the base of the tip bottoms onto the barrel.
- Press the cap end into the wide turned end of the barrel.
- Unscrew the tip, Insert the refill into the opening at the tip. Affix the refill spring. Screw the tip over.

PLUNGER:

- Press the lower end (wider) into the wide end of the plunger.
- Press the plunger cap into the (narrower) opposite opening.
- Drop the click spring into the opening at the cap end. Place the plunger, threaded side in first and screw over the spring onto the mechanism to bottom.
- The pen is ready to use by clicking on the plunger to advance or retract the refill. Unscrew the tip to replace refill.

Diagram C / Bushings #PKVPEN BU

