

**Kit Features for Magnifier:**

- 24 kt. gold plated with epoxy coating
- Sculptured cast design to match the Pen and Letter Opener Kits. PKSC-PEN
- 2" Diameter high impact, polished glass.
- Overall length 5-3/8"

**Kit Features for Letter Opener:**

- 24 kt. gold plated with epoxy coating
- Sculptured cast design to match the Pen and Magnifier Kits. PKSC-PEN
- Blade Extension: 3-1/2"
- Overall length 7-7/16"

**Required Accessories**

- 7mm Pen Mandrel
- Bushing Set #PKSC-BU
- 8mm Drill Bit: # PKPARK-8mm
- 8mm Barrel Trimmer #PK-TRIMKIT
- 2 Part Epoxy Glue or Insta-Cure (cyanoacrylate).

**Diagram A – Parts Layout**

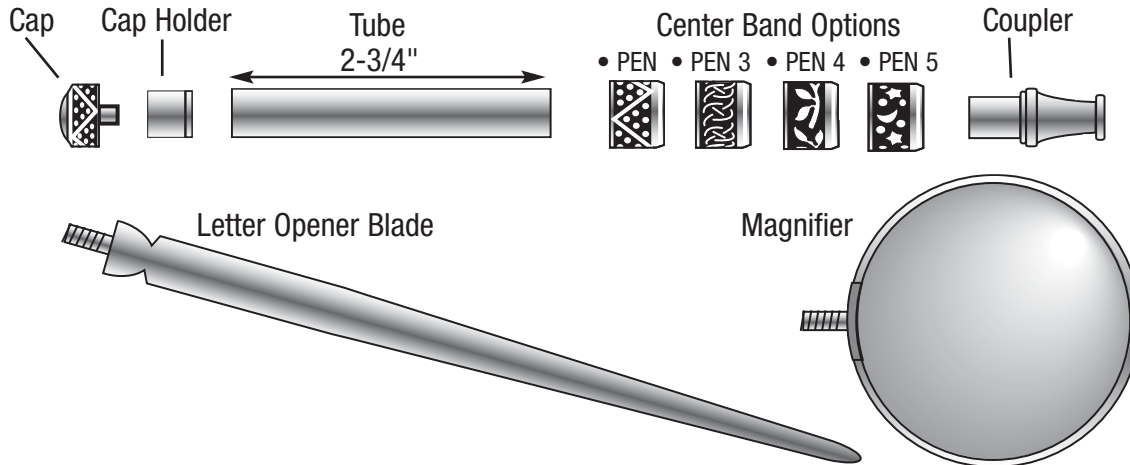

**Preparing The Blank**

- 1.) Cut 5/8" to 3/4" square blank to the length of the brass tube (add 1/16" for squaring off).
- 2.) Drill an 8mm center hole, lengthwise through the blank.
- 3.) Spread the glue over the tube. Insert the tube into the

blank with a twisting motion to spread the glue evenly inside. Center the tube lengthwise inside the blank.

- 4.) When the glue dries, square the ends of the blank. Use an 8mm barrel trimmer or a belt/disc sander to trim the wood down flush to the end of the brass tube.

**Diagram B – Turning the Blanks**

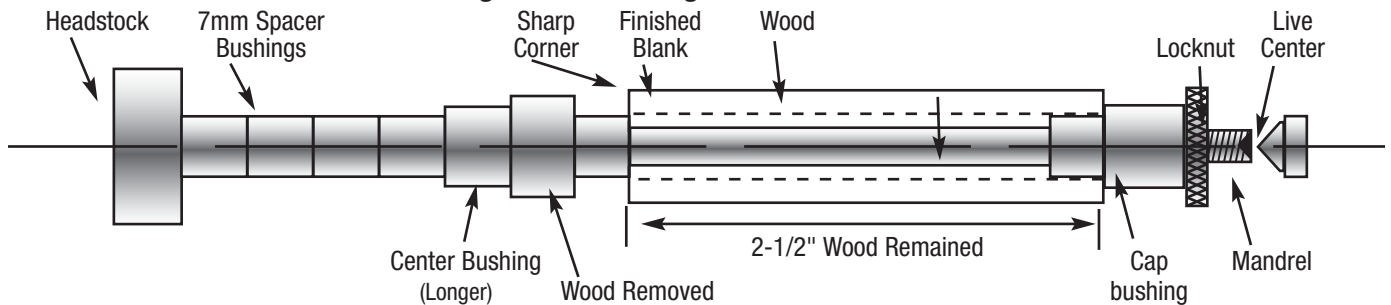

**Turning the Blanks**

- 1.) Place 7mm spacer bushings onto the mandrel. Next, place the longer cap bushing, wide diameter first, on the mandrel. Next, slide on the blank, then place the center bushing (wide dia. first) on the mandrel. Thread on the lock nut hand tight. Bring the tail stock snug with the mandrel (do not overtight, it could damage the mandrel). Lock in place.

- 2.) Using a lathe chisel, turn the blank down flush with the bushings. Finish the blank with gradual higher grits of sand paper and your choice polish and waxes.

**Removing wood for center band:**

- 3.) Use a pencil to mark 2-1/2" from the center cap bushing. Use the parting tool to remove the excess wood down to the brass tube. Be careful, you must retain a sharp 90° corner at the end of the upper blank when you remove the excess wood.
- 4.) Sand both blanks then finish the blanks with your choice of polishes and waxes.

**Diagram C - Assembly**

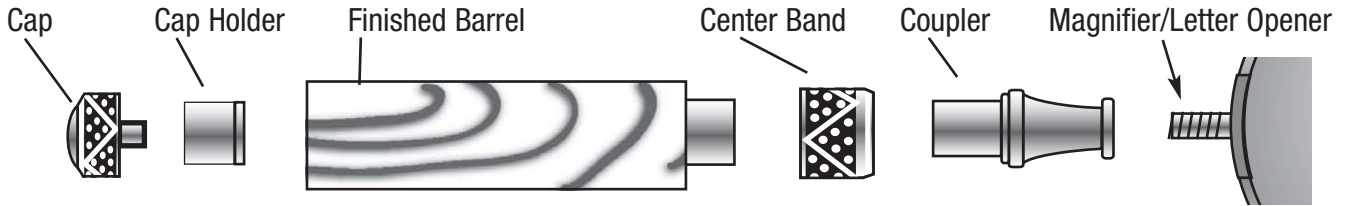

**Assembly**

- Line up finished parts according to diagram C.
- 1.) Press the cap stud into the chamfered side of the cap holder, and press it all the way in, creating the cap assembly.
  - 2.) Use two part epoxy to glue the cap assembly in the wood covered end of the barrel.
  - 3.) Press the center band, square end first, over the bare brass tube flush against the wood.
  - 4.) Use two part epoxy to glue the coupler into the center band and then press both together into the barrel until the rim and band engage.
  - 6.) Screw either the magnifier glass or the letter opener tightly into the coupler.

**Bushings - #PKSC-BU**

