

Spartan Click Pen Kit

PKRPEN24 • PKRPENCH • PKRPENGM • PKRPENAB

Kit Features:

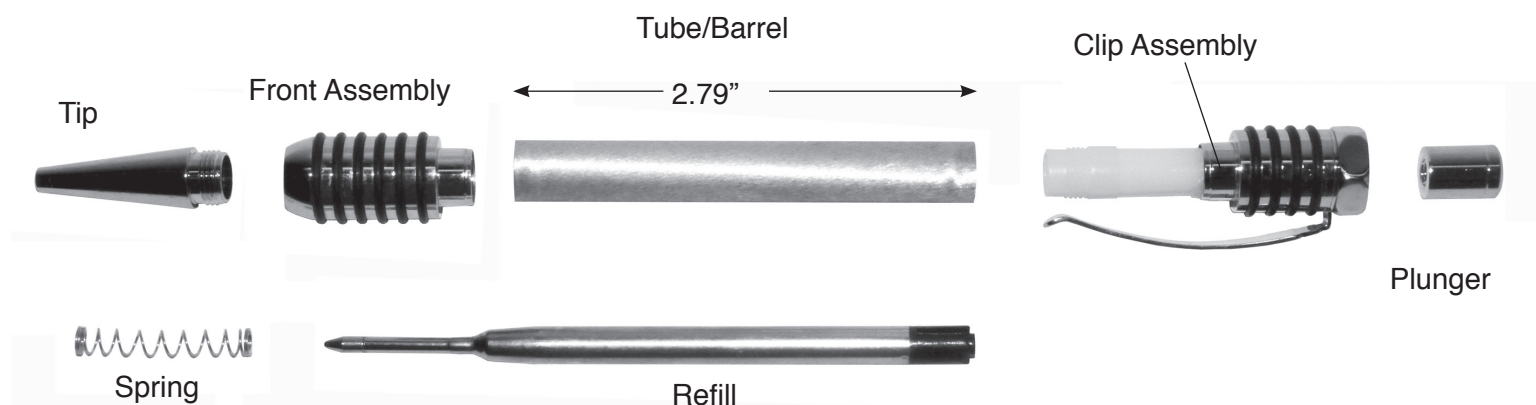
- Easy to turn with a straight tube
- Minimum parts - easy to assemble
- Uses Parker® Style refill
- Available in multiple finishes
- Smooth, advanced click motion
- Overall Length: 5-3/4" Long

Required Accessories:

- 7mm Pen Mandrel
- Drill Bit: 3/8" #PKEXEC-38
- Bushing set(2 pc) #PKMAJSQBU
- Barrel Trimming set #PKTRIM38
- Live Tailstock Center
- 2 Part Epoxy Glue or Insta Cure (Cyanoacrylate) Glue
- Pen Blank: Minimum Size - 3/4" x 3" Long

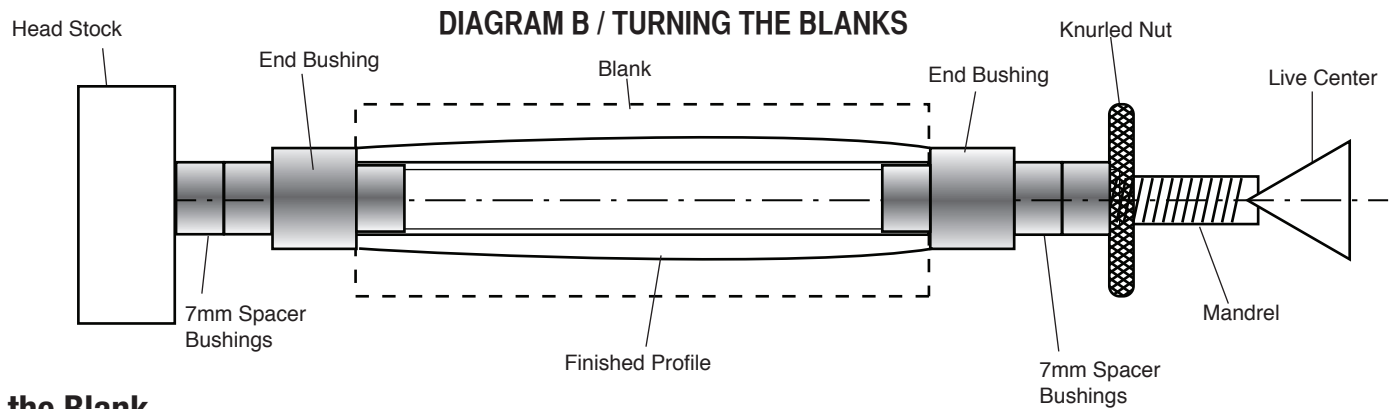


DIAGRAM A / PARTS LAYOUT



Preparing the Blank:

- Cut 1 blank to the length of the tube and add 1/16" for squaring off.
- Drill a 3/8" hole lengthwise through the blank.
- Spread glue over the tube, insert the blank with a twisting motion to spread the glue evenly inside.
- Center the tube lengthwise inside the blank.
- When the glue is dry, square the end of the blank. Use a 3/8" barrel trimmer or a universal pen blank squaring jig with a power disc sander. Take the excess material down flush with the ends of the brass tube. (do not trim beyond the length of the tube since this may interfere with operation of the mechanism and assembly).



Turning the Blank

- Mount the bushings and blanks according to diagram B.
- Thread on the knurled nut and hand tighten to hold all components in place.
- Slide the tailstock up snugly against the mandrel shaft inserting the live center point into the mandrel dimple, lock in place.
- Hand tighten the quill adjustment to firm up the mandrel. (DO NOT overtighten, it could damage the mandrel.)
- Using sharp tools, turn the blank down close to the bushing diameter. Turn the barrel (straight or to a profile of your choice)
- Sand the blank down to be flush with the bushings gradually increasing the sandpaper grits.
- Finish the barrel with your choice of polish. Allow sufficient time for the polish to cure. Refer to polish instructions.

Assembly

- Layout parts according to diagram A
- Press the front assembly, recessed end in first into either end of the barrel.
- Press the clip assembly into the opposite end of the barrel.
- Affix the spring over the tip of the refill.
- Drop the refill into the opening at the front assembly.
- Screw the tip over the refill, into the front assembly.
- Thread the plunger over the shaft of the clicker mechanism at the opposite end.
- The pen works by clicking on the plunger to advance or retract the refill tip.

Diagram C / Bushings #PKMAJSQBU

