

Premium Flashlight Kits

Required Accessories & Supplies

- 7mm, Pen Mandrel
- 3 pcs. bushing set # PKPLI-BU
- .492 #PKPLI-DB (or 12.5mm) drill bit
- Universal pen blanks squaring jig or trimming sleeve #PKOLBTS (use with 7mm shaft)
- 2 part epoxy glue or Insta Cure (cyanoacrylate) glue
- 3/4 x 3/4 x 4 1/2 long blank
- Uses 2 AAA batteries
- Overall Length: 5- 3/4"

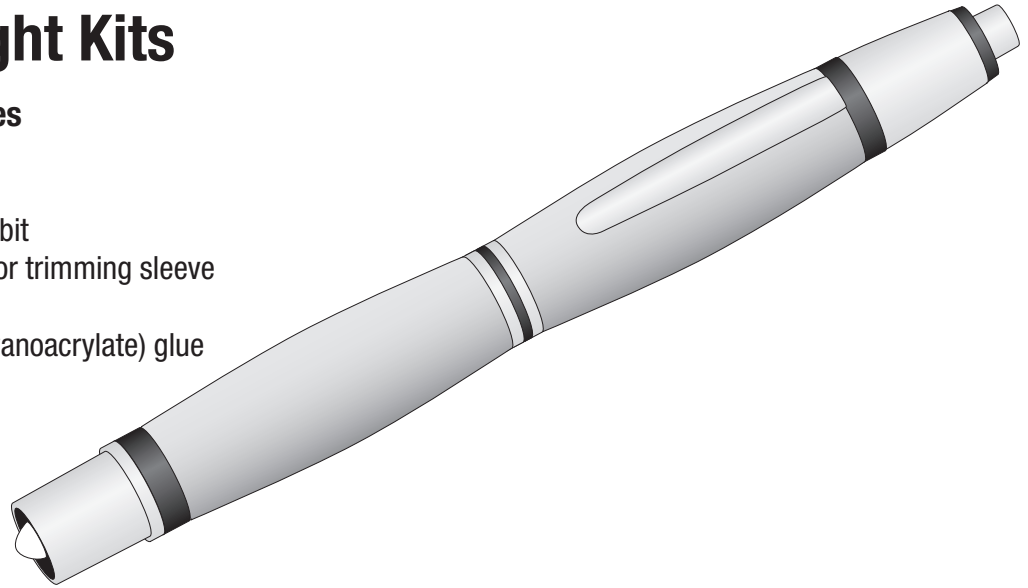
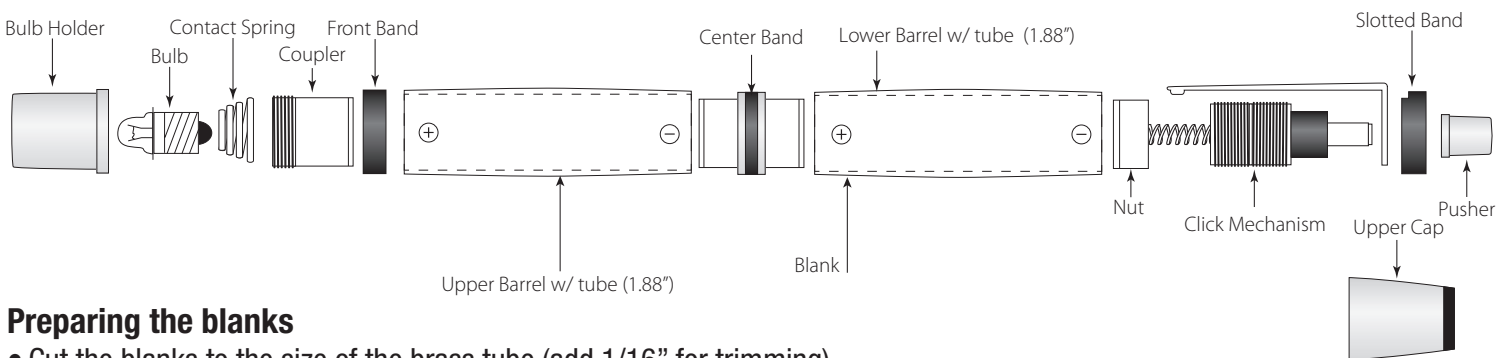

DIAGRAM A - Parts List



Preparing the blanks

- Cut the blanks to the size of the brass tube (add 1/16" for trimming)
- Drill .492 (12.5mm) hole, through each blank.
- Glue each tube in the blank. Insert with a twisting motion to spread the glue evenly inside the blank.
- When the glue dries, use a universal squaring jig or a 7mm barrel trimmer with a trimming sleeve. Trim the wood down, flush to the brass tube.

DIAGRAM B - Turning the Blanks

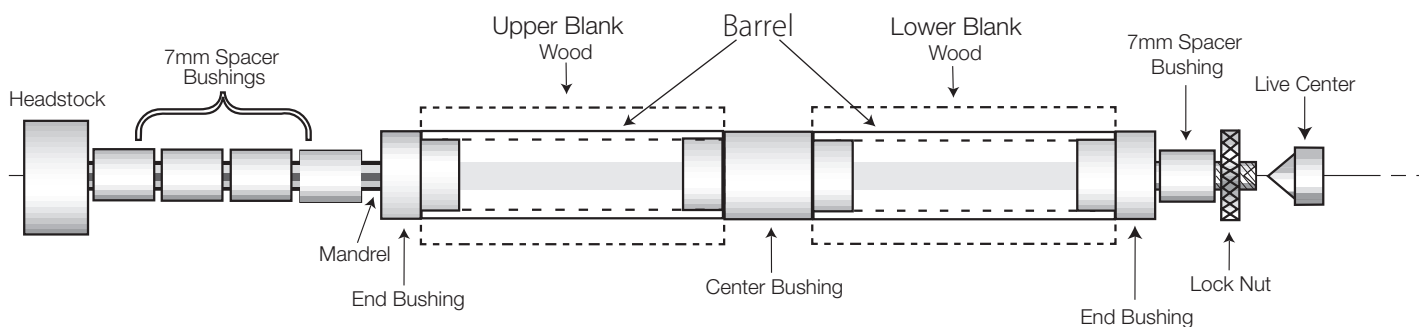

Turning the blanks

- Mount the bushings and blanks on the mandrel according to Diagram "B" (end bushings are the same)
- Turn the wood down, close to the size of the bushings. Sand the wood to the bushing diameter.
- Finish the wood with your choice of polish.

Assembly (See Diagram A)

Note: Layout finished parts according to Diagram A

- Insert the front band over the coupler, press the coupler into the upper barrel.
- Press the center band into the opposite end of the upper barrel.
- Press the lower barrel into center band.
- Press the nut, recessed end in first into the opening at the lower barrel, press flush with the wood.
- Screw the click mechanism, spring in first into the nut
- Insert the clip over the exposed threads, slide the slotted band with the slot end in first. Align with clip.
- Affix the plunger over the white stem. Thread the upper cap on. Be sure clip is seated in the slot.
- Drop 2 AAA batteries, plus side up, into the opening at the front end.
- Place the spring behind the bulb base, insert into bulb holder. Screw holder into front end of the Pen Light.
- The Pen Light is ready to operate by clicking on and off on the plunger.

DIAGRAM C - Bushing #PKPLI-BU

