

Ultra Bright Flashlight Kit V2

PKPLI3CH • PKPLI3GM

Kit Features:

- Easy to turn with straight tubes
- Minimum parts - easy to assemble
- Comfortable click on/off light switch
- Available in multiple finishes
- Ultra Bright LED Bulb
- Uses 2 AAA Batteries (*not included*)
- Replacement Bulb #PKPLILED
- Overall Length: 5-3/4"

Required Accessories:

- 7mm Pen Mandrel
- Drill Bit: 12.5MM #PKPLI-DB
- #PKPLI-BU Bushing set(3 pc)
- #PKMAJJRBTs Barrel Trimming Sleeve Set (use the larger sleeve in the set)
- 7mm Barrel Trimmer #PKTRIMKIT
- Live Tailstock Center or Mandrel Saver
- 2 Part Epoxy Glue or Insta Cure (Cyanoacrylate) Glue
- Pen Blank: Minimum Size - 3/4" square x 4-1/2" Long



DIAGRAM A / PARTS LAYOUT

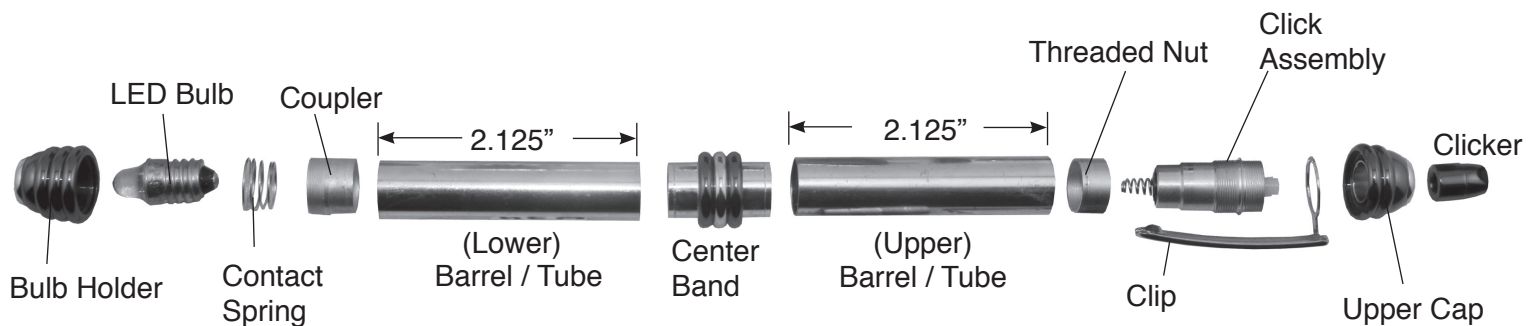

Preparing the Blank:

- Cut 2 blanks to the length of the tubes and add 1/16" for squaring off.
- Drill 12.5mm holes lengthwise through the blanks.
- Spread glue over the tubes, insert the tubes with a twisting motion to spread the glue evenly inside.
- Center the tubes lengthwise inside the blanks.
- When the glue is dry, square the ends of the blanks. Use a 7mm barrel trimmer with the proper sleeve, or a universal pen blank squaring jig with a power disc sander. Take the excess material down flush with the ends of the brass tube. (do not trim beyond the length of the tube since this may interfere with operation and the assembly). Scrape the I.D. of the tube to remove excess glue if necessary.

DIAGRAM B / TURNING THE BLANKS

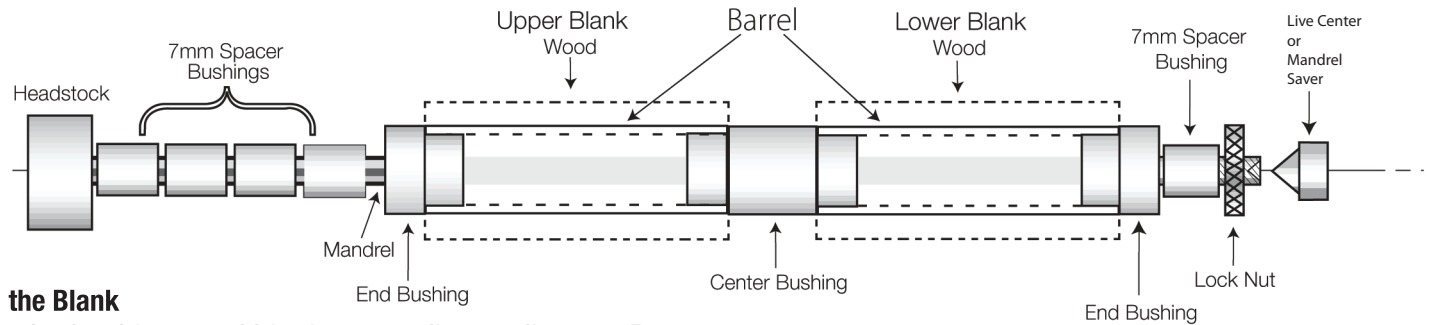

Turning the Blank

- Mount the bushings and blanks according to diagram B.
 - Thread on the knurled nut and hand tighten to hold all components in place.
 - Slide the tailstock up snugly against the mandrel shaft inserting the live center point into the mandrel dimple, lock in place.
 - Hand tighten the quill adjustment to firm up the mandrel. (DO NOT overtighten, it could damage the mandrel).
 - Using sharp tools, turn the blank down close to the bushing diameter. Turn the barrel (straight or to a profile of your choice)
 - Sand the blank down to be flush with the bushings gradually increasing the sandpaper grits.
 - Finish the barrel with your choice of polish. Allow sufficient time for the polish to cure.
- Refer to polish instructions.

Assembly

- Layout parts according to diagram A.
- Press the coupler into either barrel.
- Press the center band into the opposite end of the barrel.
- Press the upper barrel over the center band.
- Press the threaded nut recessed end in first into the upper barrel.
- Screw the click assembly into the nut.
- Affix the clip over the threads, push in the clicker over the stem of the click assembly and screw the upper cap over this assembly. Adjust the clip into the slot in the cap and tighten.
- Drop 2 AAA batteries, plus(+) side up, into the opening at the front end.
- Place the spring around the base of the bulb, insert into the bulb holder.
- Screw holder onto the coupler to bottom.
- The pen light is ready to operate by clicking the pusher.

Diagram C / Bushings #PKPLI-BU

