

## CLASSIC TRADITIONAL PEN KIT

### KIT FEATURES

- Heavy plating on PKPAR10R24 & PKPAR10F24
- Elegant, contemporary design with contrasted styling.
- 1/4 turn attaches the cap to either ends of the pen body.
- Fountain pen uses quality iridium tipped nib –convertible cartridge available
- Rollerball contains black gel refill for a smooth writing experience.
- Overall length: 5-1/8" (closed)

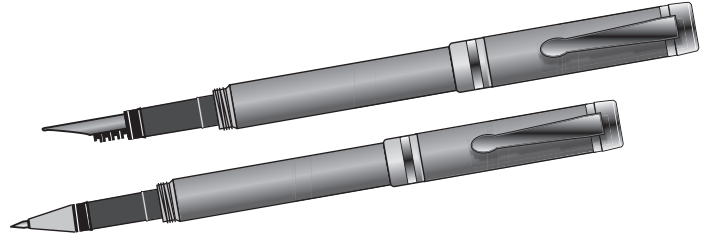

### REQUIRED ACCESSORIES:

- 7mm, long pen mandrel
- 3 pc bushing set #PKPAR10-B2
- 10mm drill bit #PK10-10
- 10mm barrel trimmer from #PKTRIMKIT
- 2 part epoxy glue or insta-cure (cyanoacrylate) glue
- Spread glue over tube. Insert into blank with twisting motion to spread the glue evenly inside. Center tube lengthwise in the blanks.
- When the glue dries, square the ends of the blanks. Use a 10mm barrel trimmer or belt/disc sander to trim the wood down flush to the end of the brass tubes.

### PREPARING THE BLANK

- Cut 3/4" to 5/8" square blanks to the length of the brass tubes (add 1/16" for squaring off).
- Drill a 10mm center hole lengthwise through each blank.

### DIAGRAM B / Turning the Blank

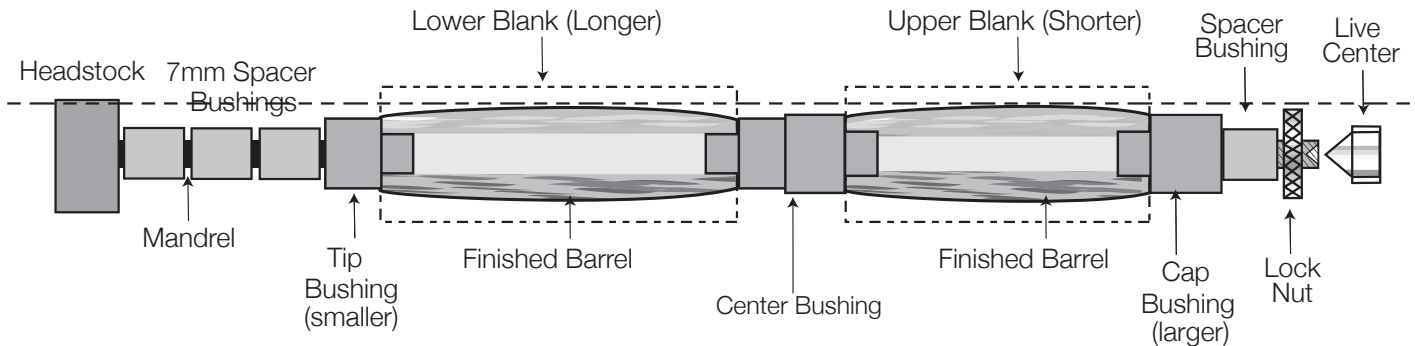

### TURNING THE BLANK

- Refer to Diagram B - Insert 3-4, 7mm spacer bushings onto the mandrel shaft. Place the tip bushing (smaller diameter) wide-end in first. Slide on the lower blank (longer), place the center bushing narrow-end first on the mandrel.
- Next, slide the upper blank (shorter) and follow with the larger diameter cap bushing, narrow diameter on first. Use 7mm spacer bushings to fill the space to the thread. Thread on the lock nut and hand-tighten.
- Bring the tail stock snug with the mandrel hand tighten the lock nut (do not overtighten – it will damage the mandrel).
- Turn the wood down, flush with the bushings using a lathe chisel and gradual higher grits of sandpaper.
- Sand both blanks, then finish the blanks with your choice of polish and waxes.

### DIAGRAM F #PKPAR10-B2

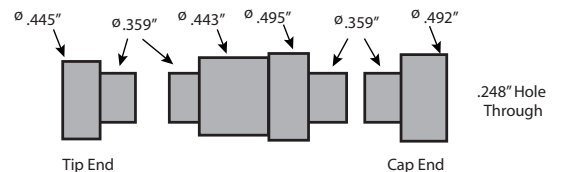

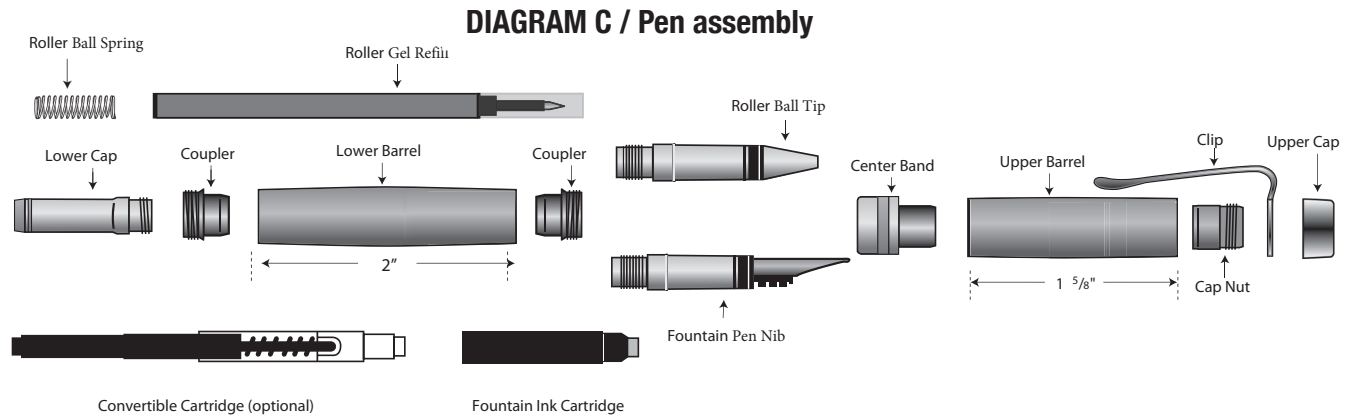

### ASSEMBLY TIPS

- Line up finished parts according to Diagram C.
- To press parts in, use a pen vise or a vice with covered jaws.
- Press parts slowly to avoid scratching and damaging the gold plated parts.

### ASSEMBLY OF BODY BARREL:

- Press a coupler into each end of the Lower barrel.
- Screw in the lower cap into either end of the barrel.
- Choose appropriate pen style for final assembly;

### ASSEMBLY OF CAP BARREL:

- Press the center band, narrow diameter in first into the opening at either end of the barrel.
- Insert and press the cap nut, recessed end in first into the opposite end of the barrel. Stop at the shoulder.
- Insert the clip over the threads, screw on the upper cap.

### FOUNTAIN PEN ASSEMBLY:

- Push the ink cartridge (narrow end first) into the open end of the nib assembly to the end to cut an opening and allow the ink to flow. Screw this assembly into the barrel.
- Tip: Stroke the pen nib from the small hole to the tip with a damp paper to help start the ink flow.*
- OR – when using the refillable cartridge, push the clear end of the cartridge into the opening of the nib assembly until it clicks. Screw the inner shaft counter clockwise all the way down inside the cartridge. Now, dip the nib into an ink bottle and slowly turn the shaft upwards (clockwise) to draw ink in, until the reservoir is filled. Screw the nib assembly back into the barrel.

### ROLLERBALL PEN ASSEMBLY:

- Drop the refill spring into the opening of the lower barrel. Remove the protective cover of the refill. Insert into the barrel rear end first.
- Screw the roller ball tip over the refill. Rollerball is ready to operate.

### OPERATING THE PEN:

- A quick 1/4 turn will screw the ends together. When using the pen, screw the cap over the body end. Always keep the nib covered when not in use to avoid ink from drying up.