

# "Classic Elite" Rollerball & Fountain Pens

**REVISED**  
10/03

## Kit Item:

**#PKPAR-RCEG – Gold Rollerball Pen**  
**#PKPAR-RCES – Satin Rollerball Pen**

**#PKPAR-FCEG – Gold Fountain Pen**  
**#PKPAR-FCES – Satin Fountain Pen**

## Kit Features:

- Heavy plating with either 24kt gold, or satin finishing.
- Elegant, contemporary design combined with old and new styling.
- Screw on cap with quarter turn threads to attach to either ends of the pen.
- Fountain pen uses quality iridium tipped nib, made in Germany – convertible cartridge available
- Rollerball contains black gel refill for a smooth, new experience in writing
- Overall length: 5-1/8" (closed)

## Required Accessories:

- 7mm, long mandrel
- 3 pc bushing set **#PKPAR10-B2**
- 10mm drill bit **#PK10-10**
- 10mm barrel trimmer **#PKTRIMKIT**
- 2 part epoxy glue or insta-cure (cyanoacrylate) glue

## Diagram A: PARTS LAYOUT

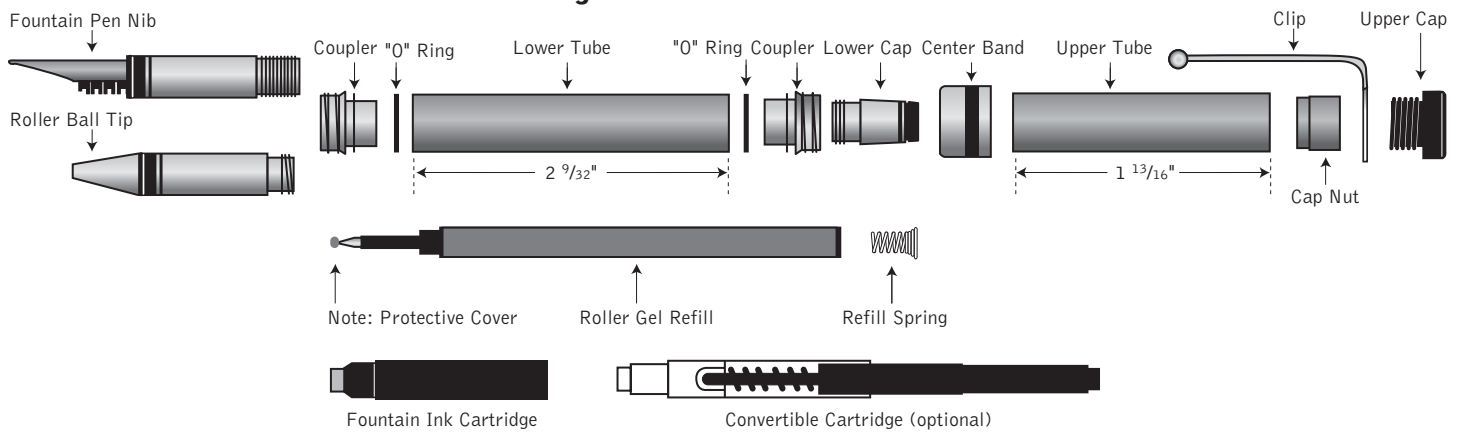

## PREPARING THE BLANKS FOR TURNING

- Cut 3/4" to 5/8" square blanks to the length of the brass tubes (add 1/16" for squaring off).
- Drill a 10mm center hole lengthwise through each blank.
- Spread glue over tube. Insert into blank with a twisting motion to spread the glue evenly inside. Center each tube lengthwise in the blanks.
- When the glue dries, square the ends of the blanks. Use a 10mm barrel trimmer or belt/disc sander to trim the wood down flush to the end of the brass tubes.

## Diagram B: TURNING THE BLANKS

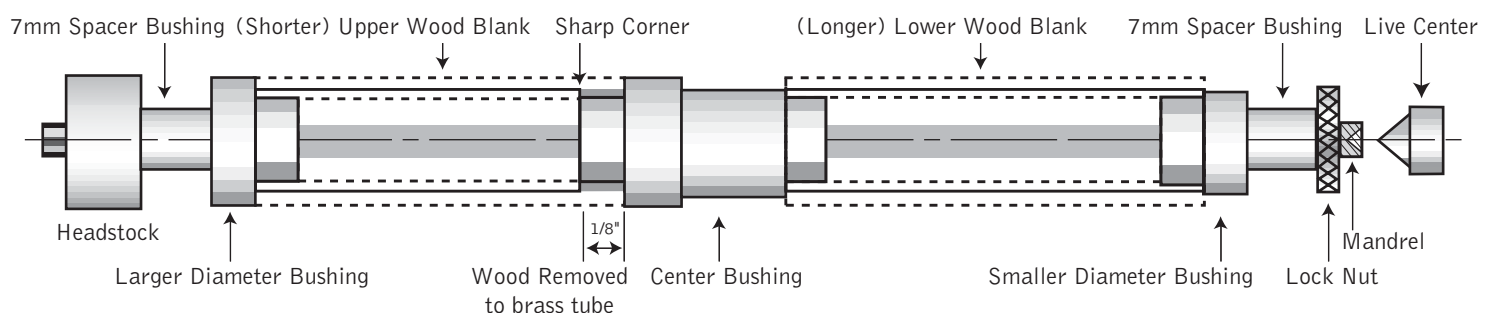

## TURNING THE BLANKS

- Insert 3-4, 7mm spacer bushings onto the mandrel shaft. Place the upper cap bushing (larger diameter) wide-end in first. Slide the upper blank (smaller diameter), place the center bushing wide-end in first on the mandrel. Next, slide the lower blank (longer) and follow with the smaller diameter bushing, narrow diameter on first. Use 7mm spacer bushings to fill the space to the thread. Thread on the lock nut and hand-tighten. Bring the tail stock snug with the mandrel hand tighten the lock nut (do not overtighten – it will damage the mandrel).
- Turn the wood down, flush with the bushings using a lathe chisel and gradual higher grits of sandpaper.

### Removing Wood for Center Band:

- Use a pencil to mark 1/8" from the center bushing on the upper barrel. Use a parting tool to remove the excess wood down to the brass tube. Be careful, you must retain a sharp 90 degree corner at the end of the upper blank when you remove the excess wood.
- Sand both blanks, then finish the blanks with your choice of polish and waxes.

## FOUNTAIN PEN ASSEMBLY:

### Assembly of Body Barrel:

- Line up and identify finished parts according to Diagram A.
- Insert an “O” ring into the groove at the thread of each coupler.
- Press a coupler into each end of the barrel.
- Screw in the plastic end cap (either end).
- Push the ink cartridge (narrow end first) into the open end of the nib assembly to the end to cut an opening and allow the ink to flow. Screw this assembly into the barrel.

**Tip:** Stroke the pen nib from the small hole to the tip with a damp paper to help start the ink flow.

- **OR** – when using the refillable cartridge, push the clear end of the cartridge into the opening of the nib assembly until it clicks. Screw the inner shaft counter clockwise all the way down inside the cartridge. Now, dip the nib into an ink bottle and slowly turn the shaft upwards (clockwise) to draw ink in, until the reservoir is filled. Screw the nib assembly back into the barrel.

### Assembly of the Cap Barrel:

- Press the cap nut, recess end first, into the flat end of the barrel.
- Press the center band (square end first) over the exposed end of the brass tube to the wood. Use a drop of glue, if necessary.
- Insert the threaded stud on the upper cap into the hole in the clip. Next, thread this assembly tightly into the cap nut.

### Operating the Pen:

- The Fountain Pen is ready to operate. A quick 1/4 turn will screw the ends together. When using the pen, screw the cap over the body end. Always keep the nib covered when not in use to avoid the ink from drying up.

## ROLLERBALL PEN ASSEMBLY:

### Assembly of Body Barrel:

- Line up and identify finished parts according to diagram A.
- Insert an “O” ring into the groove at the thread of each coupler.
- Press a coupler into each end of the barrel.
- Screw in the plastic lower cap (either end).
- Drop the spring into the barrel. Remove the cover from the ink refill and insert the flat end inside the barrel. Screw on the tip over the point.

### Assembly of Cap Barrel:

- Press the center band (square end first) over the exposed end of the brass tube to the wood. Apply glue, if necessary.
- Insert the threaded stud on the upper cap into the hole in the clip. Next, thread this assembly tightly into the cap nut.

### Operating the Pen:

- The Rollerball pen is ready to operate. A quick 1/4 turn will screw ends together. When using the pen, screw the cap over the body end. Always keep the tip covered when not in use to avoid the ink from drying up.

### BUSHING SET: #PKPAR10-B2



Larger Diameter Bushing

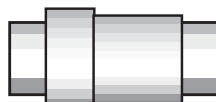

Center Bushing



Smaller Diameter Bushing