

Montague Twist Pen Kit

Kit Features:

- Easy to turn with a single tube
- Minimum parts - easy to assemble
- Available in multiple finishes
- Uses Parker™ style refill
- Overall length: 5-1/2"

Required Accessories:

- 7mm Pen Mandrel
- Drill Bit - 3/8" #PKEXEC-38
- Bushing set (2 pc) #PKGAFBU
- Barrel Trimming #PKTRIMKIT or #PKTRIM38
- Live Tailstock Center
- 2 Part Epoxy Glue or Insta Cure (Cyanoacrylate) Glue
- Pen Blank: Minimum Size - 3/4" x 3-1/2" Long



DIAGRAM A / PARTS LAYOUT

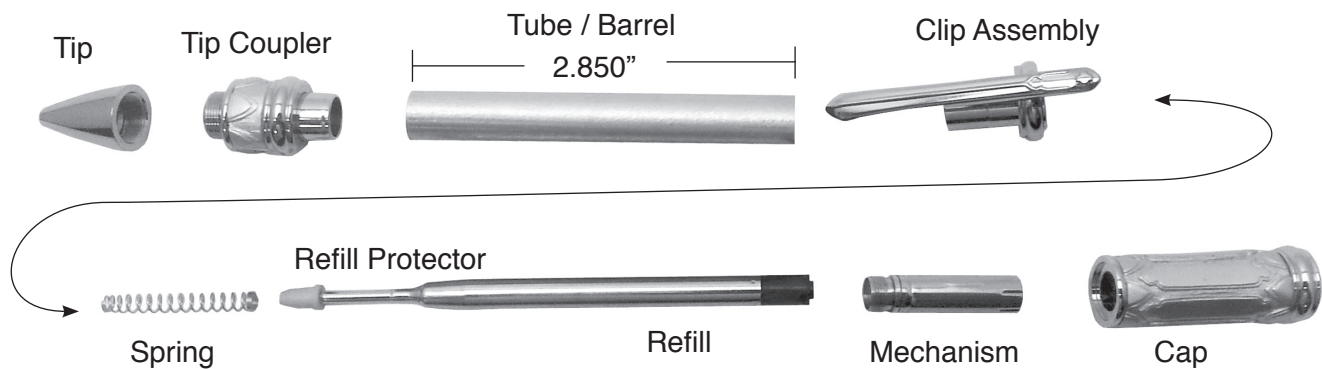

Preparing the Blank:

- Cut 1 blank to the length of the tube and add 1/16" for squaring off.
- Drill a 3/8" hole lengthwise through the blank.
- Spread glue over the tubes, insert into the blank with a twisting motion to spread the glue evenly inside.
- Center the tube lengthwise inside the blank.
- When the glue is dry, square the ends of the blank. Use 3/8" barrel trimmer, or a universal pen blank squaring jig with a power disc sander. Take the excess material down flush with the ends of the brass tube. (do not trim beyond the length of the tube since this may interfere with operation of the mechanism and assembly). Use a barrel trimmer to clean the inside of the tube.

DIAGRAM B / TURNING THE BLANKS

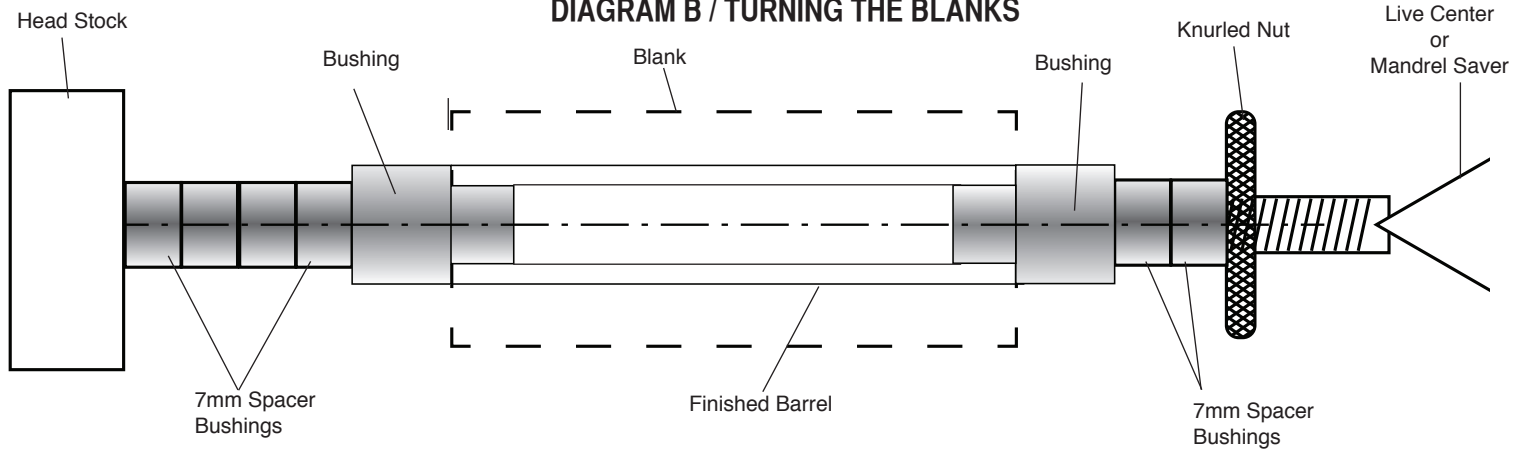
**Turning the Blank**

- Mount the bushings and blanks according to diagram B.
- Thread on the knurled nut and hand tighten to hold all components in place.
- Slide the tailstock up snugly against the mandrel shaft inserting the live center point into the mandrel dimple, lock in place.
- Hand tighten the quill adjustment to firm up the mandrel. (DO NOT overtighten, it could damage the mandrel.
- Using sharp tools, turn the blank down close to the bushing diameter. Turn the barrel (straight or to a profile of your choice)
- Sand the blank down to be flush with the bushings gradually increasing the sandpaper grits.
- Finish the barrel with your choice of polish. Allow sufficient time for the polish to cure. Refer to polish instructions.

Assembly

- Layout parts according to diagram A
- Press the tip coupler, recessed end in first into either end of the barrel. Avoid pressing directly against the threads.
- Insert and press the clip assembly into the opposite end of the barrel.
- Screw the tip over the threaded end of the tip coupler.
- Remove the protector off the refill. Affix the spring over the tip and drop this into the opening at the clip assembly.
- Screw the twist mechanism in behind the refill.
- Insert and push the cap over the exposed end of the mechanism.
- The pen is ready to operate by twisting the ends to advance or retract the refill tip.

Diagram C / Bushings #PKGAFBU