

The Compson Pen Kit

PKJPENCH • PKJPENGT • PKPKJPENBT

Kit Features:

- Improved, Trouble free click mechanism.
- Uses Parker® style refill.
- Overall length: 5-1/4"
- Easy to turn and assemble. Single tube design.

Required Accessories:

- 7mm, pen mandrel.
- 3/8" Drill bit #PKEEXEC-3/8"
- 2 pc. bushing set #PKJPENBU
- Universal barrel trimming set #PKTRIMKIT (use 3/8" shaft)
- 2 Part epoxy glue or, insta-cure (cyanoacrylate) glue
- Live Center



DIAGRAM A / PARTS LAYOUT

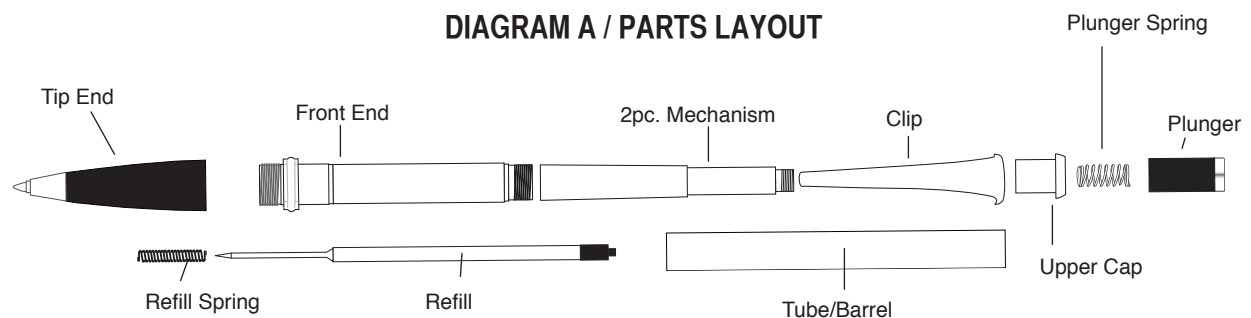

Preparing the Blanks:

- Cut a 5/8" blank to the size of the brass tube (add 1/16" for trimming the ends).
- Drill a 3/8" center hole lengthwise through the blank.
- Spread glue over the tube, insert into the blank with a twisting motion, to spread the glue evenly inside, center the tube in the blank
- When the glue dries, use a 7mm barrel trimmer to square the ends of the blank. Take the wood down to the brass tube. Do not over trim or leave excess glue inside the tube since this may cause problems with the mechanism function.

