

Small Pepper Mill Kit

Kit Features:

- Easy to hold in the palm of your hand
- Requires only drilling two hole sizes
- Ceramic grinding parts can use salt or pepper
- Only 3-3/4" tall

Required Accessories:

- 7mm Pen Mandrel
- Drill Bit(s):
 - 1-1/16" #FBI-116 (For thru holes)
 - 36mm #FB36MM (For top recess)
 - 1-1/2" #FB150 (For bottom recess)
- PKGRIND7BU Bushing set(2 pc)
- Small Phillips Screw Driver
- 60° Live Tailstock Center
- Wood Blank Required: Minimum Size- 2" x 2" x 3-1/4" H



Drilling the Blank

- Square the ends of the blank to start.
- Locate and mark the center of each end of the blank.
- Bore a 36mm hole 3/16" deep in the top of the blank.
- Bore a 1-1/16" hole half way through the top of the blank.
- Bore a 1-1/2" hole 3/8" deep in the bottom of the blank.
- Bore a 1-1/16" through the bottom of the blank to meet up with the top hole.

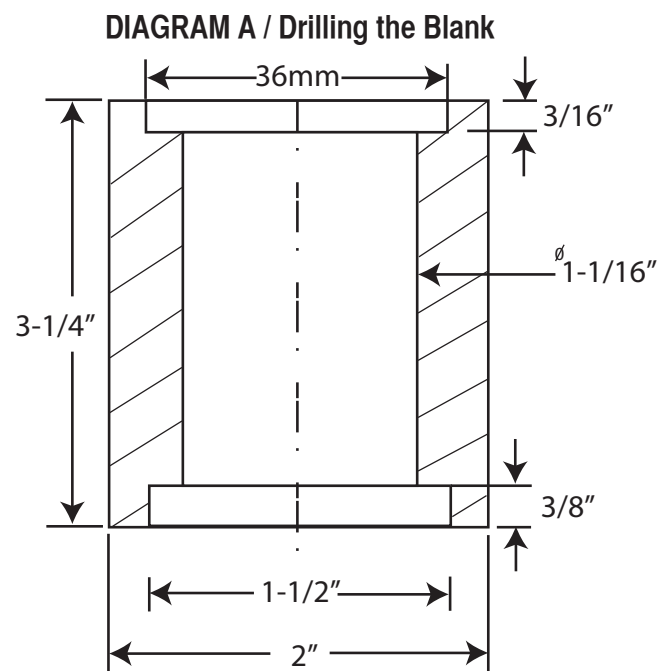
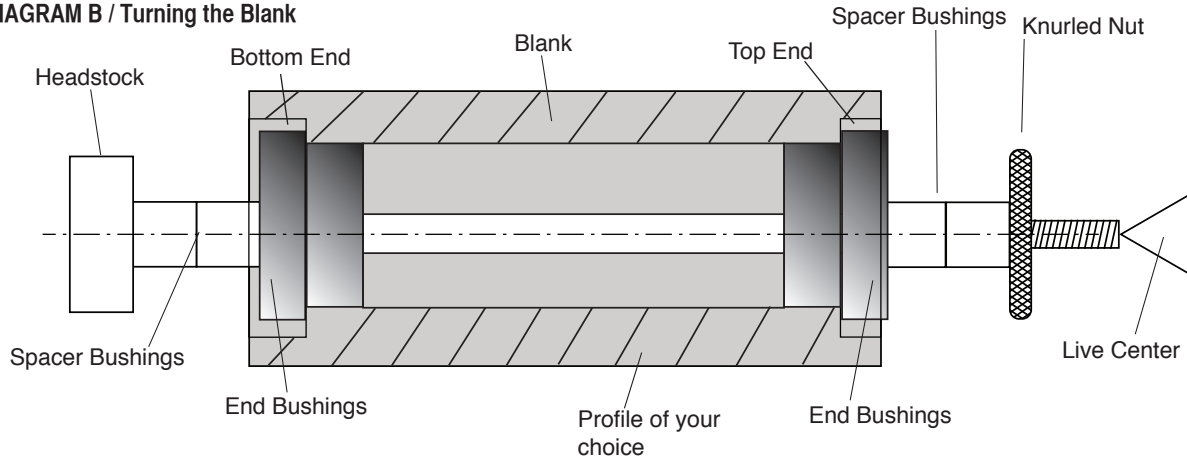

DIAGRAM B / Turning the Blank



Turning the Blank (see diagram B)

- Mount an end bushing wide end first on the mandrel.
- Slide the blank on the mandrel onto the bushing.
- Mount the other end bushing, narrow end in first into the blank.
- Lock the setup tight on the mandrel, secure with the tail stock.
- Turn the blank into the profile desired. Finish the wood with a food safe finish.

NOTE: The wood is not turned down to meet the bushings

Diagram C Grind Assembly

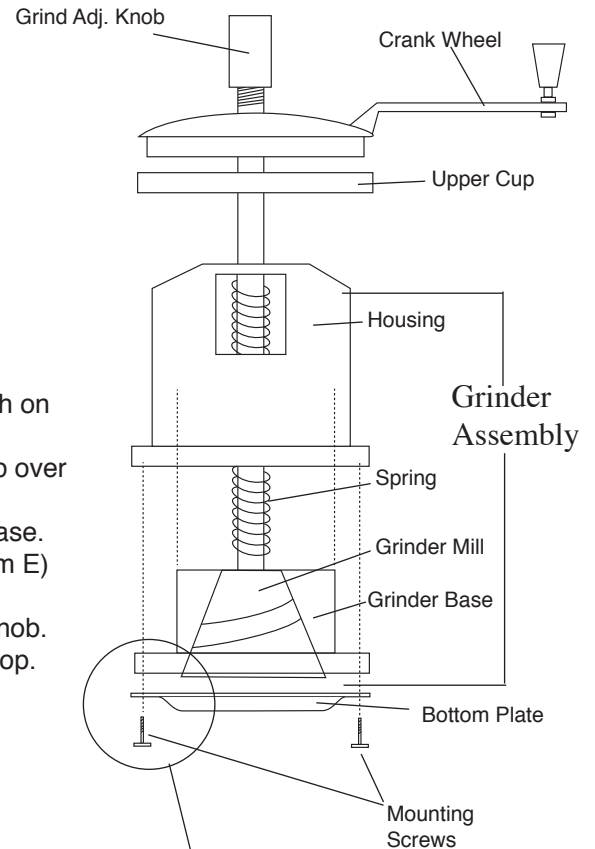

Assembly

- Layout parts according to diagram C
- Glue the upper cup into the recess on the upper blank.
- Insert the grinding assembly, shaft in first through the hole in the bottom. Push on the spring.
- Mount the crank wheel over the extended rod. Screw the adjusting grind knob over the threads.
- Line up the grinder housing rim shoulders to match the holes in the grinder base. Cover with the bottom plate, extended portion toward the bottom (see diagram E) Screw in through the grinder base and housing securely into the wood.
- When filled with pepper or salt, to adjust the grind just loosen or tighten the knob.
- To reload the mill, remove the knob and crank wheel and reload through the top.

Diagram D / Bushings #PKGRIND7BU

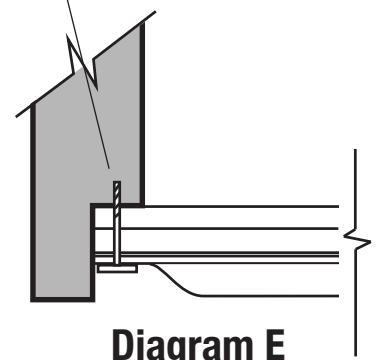
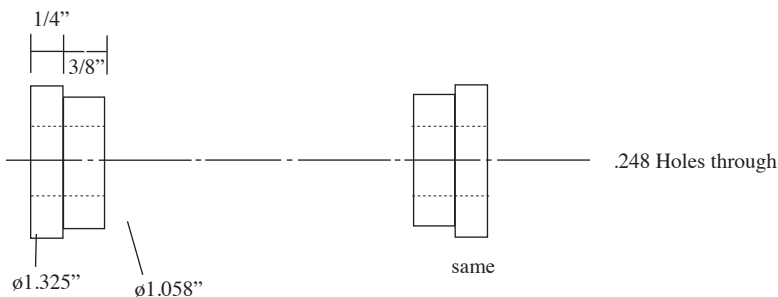

Diagram E

