

# Midi 6-1/2" Peppermill Kit

**Required Wood Blank: 3" x 3" x 5-3/4"**

## Required Accessories:

- 21/32" Drill bit #PK-2132
- 1-1/16" Forstner Drill bit #FB1-116
- 1-1/2" Forstner Drill bit #FB150
- Forstner Bit Extender #FEX
- Headstock Drill Chuck #TMXX
- 60° Heavy Duty Live Center #LCENTX
- 1" Expanding Jam Chuck #CJAM1
- Overall Height: 6-1/2"



## Boring The Blank (see Diagram A)

- Mark the center on each end of the blank. To do this, use a ruler to draw a line diagonally from corner to corner. Where the lines meet is the center.

Starting at one end of the blank:

- Bore a 1-1/2" hole 3/8" deep.
- Bore a 1-1/16" hole 4" deep, measuring from the end. Use extension (#FEX) for this.

From the other side of blank:

- Drill a 21/32" hole through the remaining wood.

## Turning The Blank (see Diagram B)

- Attach a 3 jaw headstock drill chuck into the headstock of the lathe. Insert a 1" rubber jam chuck and lock the jaws.
- Insert the rubber jam chuck into the 1-1/16" hole. Use the expanding nut to tighten the chuck inside the hole.
- Bring the tail stock live center into the hole, tighten and lock in the place.
- Turn the blank to the desired profile. Sand and finish the wood.

**Diagram A**

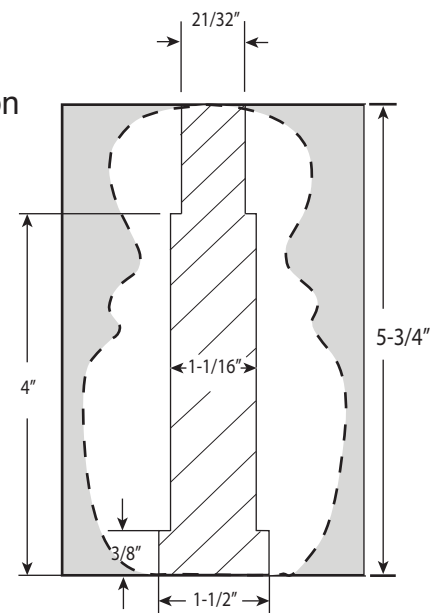

**Diagram B**

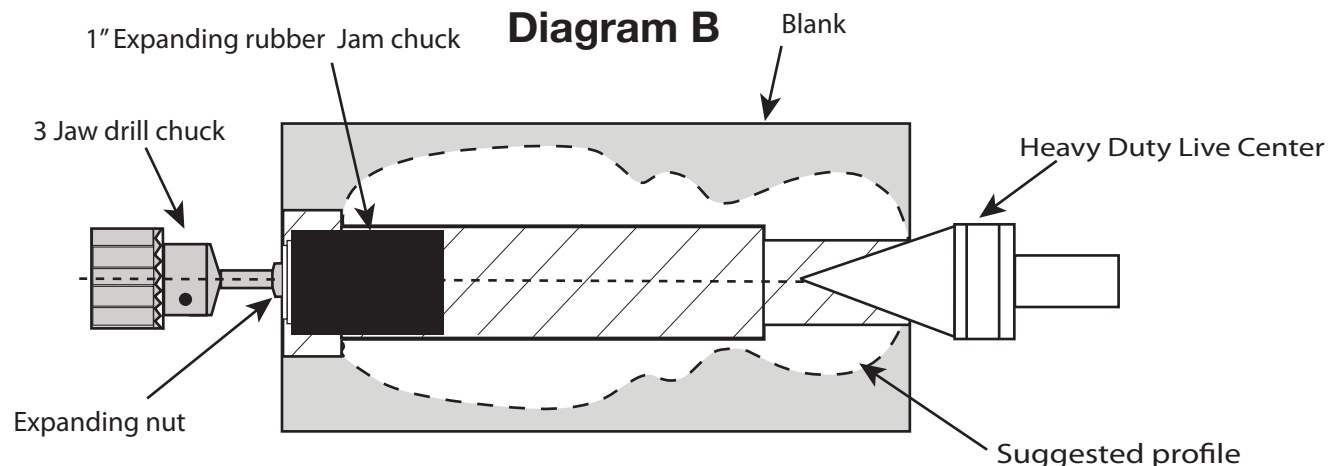

## Assembly (see Diagram C)

- Insert the bottom plate, projected side toward the bottom. Mark the mounting holes on the recess of the wood. Drill or punch pilot holes for the mounting screws (2).
- Turn the blank over, insert the handle stem into the 21/32" hole at the top. It needs to spin loose in the hole. If it is not, just sand the hole larger until it does.
- Position the grinder, grinder mill, spring, and grinder housing all mounted on the grinding shaft in this order per diagram C. Push this assembly up through the bottom hole. Place the handle over the shaft through the slot. Screw on the adjusting nut.
- Turn the project over, match the mounting slots with the mounting holes at the bottom. Align the mounting plate and secure with the provided screws.
- To adjust the grind, just loosen or tighten the adjusting nut.
- To reload the grinder. Remove the adjusting nut and handle and refill the container through the top.

### Diagram C

