

Vintage Salt & Pepper Mill

Kit Features:

- Classy retro vintage/steampunk styling
- Includes adjustable Ceramic Grinder suitable for grinding either salt or pepper
- New easy mount™ grinder capsule assembly
- Cast metal component with salt safe plastic liner
- Make a Salt/Pepper grinder set
- 6-1/2" overall height

Required Accessories:

- 1" Forstner Bit, item #FB1
- 1½" Forstner Bit, item #FB150
- 1" Jam Chuck, item #CJAM1
- Grinder positioning jig (see Diagram C)
- Epoxy Glue
- 3 Jaw Drill Chuck
- Wood required: 2-1/4" or larger sq x 3-3/4" (Finished size)

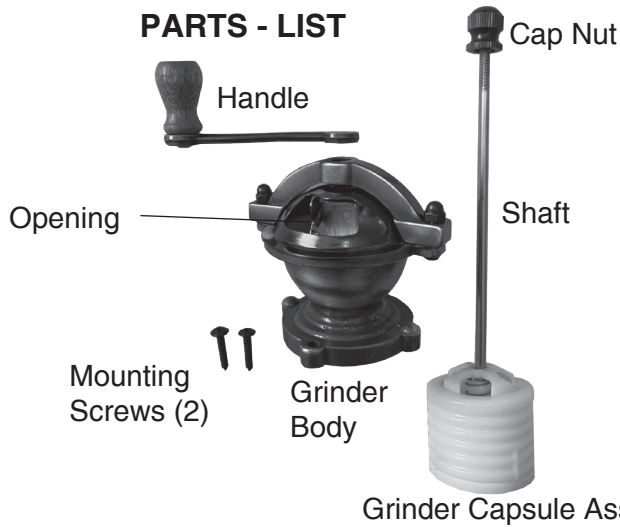

*Capsule assembly includes spring, Grinder stone, Grinder housing and Mounting components - Glues into mill housing

Preparing the Blank

- Cut a square 90-degree blank to size
- Mark the center of both ends to size
- Drill a 1" hole, 1" deep into one end
- Drill a 1½" hole at the opposite end to meet

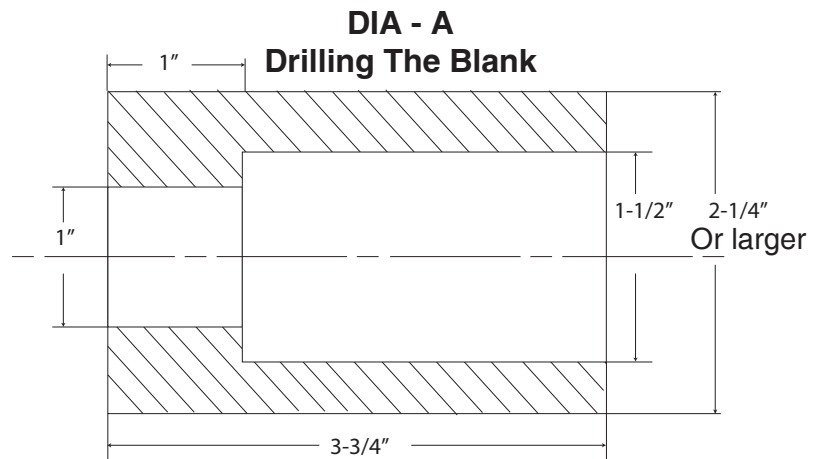

Dia B**Mounting & Turning the Blank**

Turn between centers as shown in Dia B below

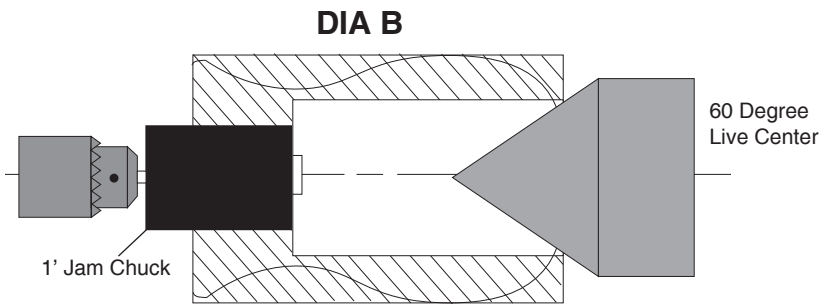
**Dia C****Using the Jig**

Use Jig to position capsule for proper Assembly height Inside shaft

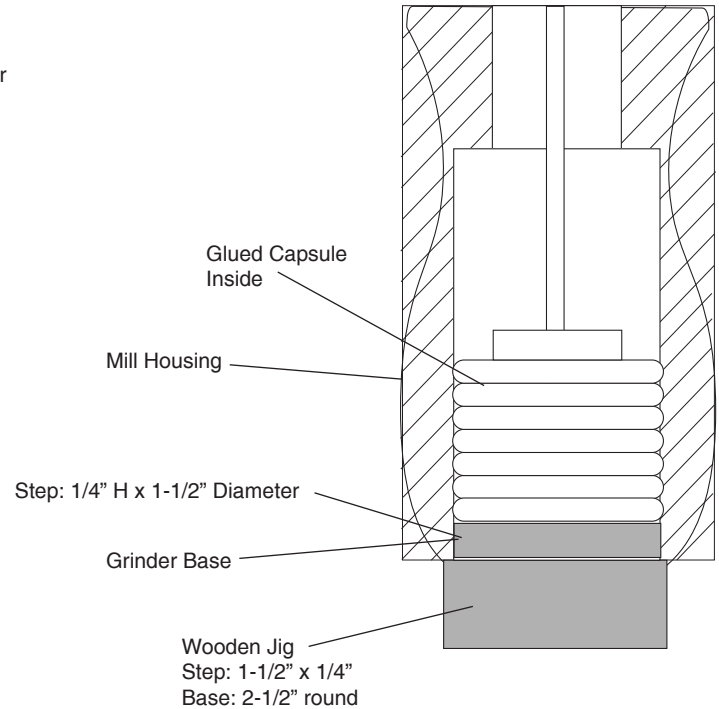
**NOTE:**

In order to determine the position of the grinder mechanism for gluing, a simple shop turned jig is helpful

Assembly

- Glue the grinding capsule into the hole in the wooden base 1/4" up from base
- Mix and spread epoxy glue over the ribs of the grinder assembly
- Insert the capsule through the bottom of the finished wood, to bottom on over the jig. See Diagram C. Let dry
- Slide the grinder body over the shaft. The threaded shaft should protrude about a 1/4" through the top of the grinder body. Position the body over the housing and mark the position of the mounting screws. Screw into the wood.
- Insert the handle over the thread shaft
- Thread on the cap nut over the shaft
- Pour rock salt or pepper in through the sliding opening. Adjust the grind by turning the cap nut up or down, for fine or course grind