

The Post Graduate Pen Kit

PKGRAP24 • PKGRAPCH • PKGRAPGM

Kit Features:

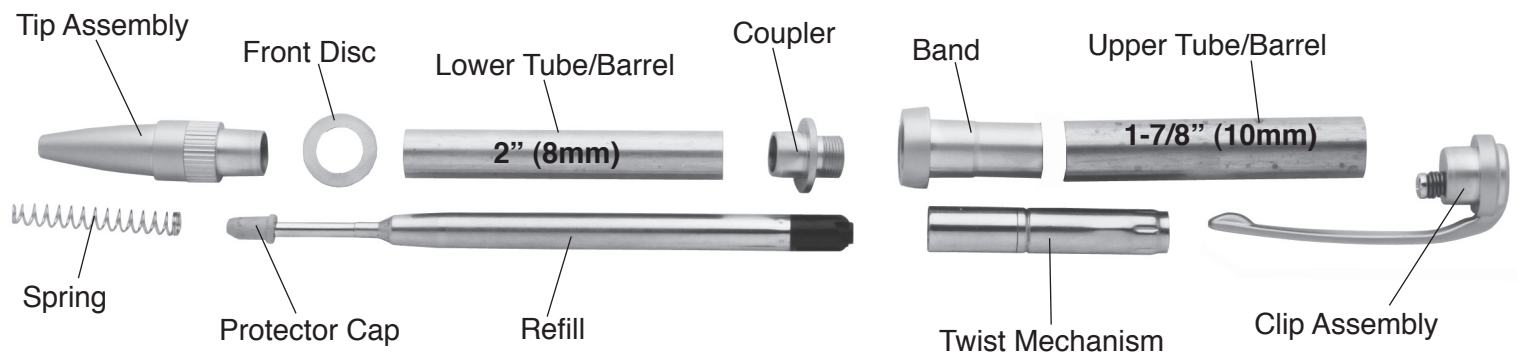
- Stylish, medium size pen
- Minimum parts - easy to assemble
- Available in multiple finishes
- Uses Parker Style Refill - Twist Action
- Convenient Spring Action Clip
- Overall Length: 5-9/16"

Required Accessories:

- 7mm Pen Mandrel
- Drill Bit(s): 8mm #PKPARK-8MM, 10mm #PK10-10
- #PKGRAPBU Bushing set (3 pc)
- #PKTRIMKIT Barrel Trimming set (use 8&10mm shafts)
- Live Tailstock Center or Mandrel Saver
- 2 Parts Epoxy Glue or Insta Cure (Cyanoacrylate) CA Glue
- Pen Blank: Minimum Size - 3/4" x 5" L

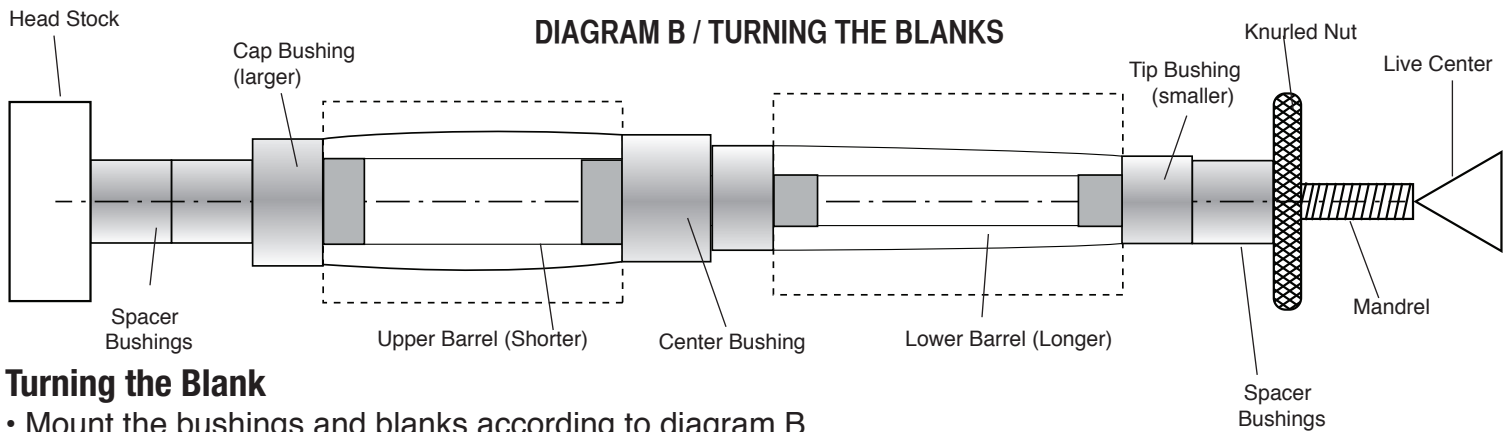


DIAGRAM A / PARTS LAYOUT



Preparing the Blank:

- Cut 2 blanks to the length of the tubes and add 1/16" for squaring off.
- Drill 8 & 10mm holes lengthwise through the blanks. Lower tube (longer) 8mm, Upper tube (shorter) 10mm.
- Spread glue over the tube(s), insert the blank with a twisting motion to spread the glue evenly inside. Center the tubes lengthwise inside the blanks.
- When the glue is dry, square the ends of the blanks. Use a 8mm barrel trimmer for the lower tube and a 10mm barrel trimmer for the upper tube. Take the excess material down flush with the ends of the brass tube. (do not trim beyond the length of the tube since this may interfere with operation of the mechanism and assembly).



Turning the Blank

- Mount the bushings and blanks according to diagram B.
- Thread on the knurled nut and hand tighten to hold all components in place.
- Slide the tailstock up snugly against the mandrel shaft inserting the live center point into the mandrel dimple, lock in place.
- Hand tighten the quill adjustment to firm up the mandrel. (DO NOT overtighten, it could damage the mandrel.
- Using sharp tools, turn the blank down close to the bushing diameter. Turn the barrel (straight or to a profile of your choice).
- Sand the blank down to be flush with the bushings gradually increasing the sandpaper grits.
- Finish the barrel with your choice of polish. Allow sufficient time for the polish to cure.
Refer to polish instructions.

Assembly

- Layout parts according to diagram A
- Press the clip assembly into either end of the upper barrel.
- Press the band, extension end in first, into the opposite end of the barrel.
- Insert the front disc over the extension of the tip assembly. Press this assembly into either end of the lower barrel.
- Insert the coupler, recessed end in, into the opposite end of the lower barrel.
- Remove the protector cap off the refill. Insert the spring over and drop into the opening at the coupler. Follow with the mechanism. Screw the mechanism over the refill end.
- Engage both ends of the pen. Twist the ends to either extend or retract the refill.

Diagram C / Bushings #PKGRAPBU

