

Gatsby Click Pen Kit

Kit Features:

- Smooth clip operation
- Pen uses Parker® Style Refill
- Overall size: 5 - 11/16"

Required Accessories:

- 7mm Pen Mandrel
- 27/64" Drill bit #PK-2764
- 2pc bushing set #PKGABU
- Barrel trimming sleeve #PKGABTS
- Universal trimming kit #PKTRIMKIT or #PKTRIM7
- 2-part epoxy glue or insta-cure (cyanoacrylate) glue



DIAGRAM A-1 • Parts list for Click Pen

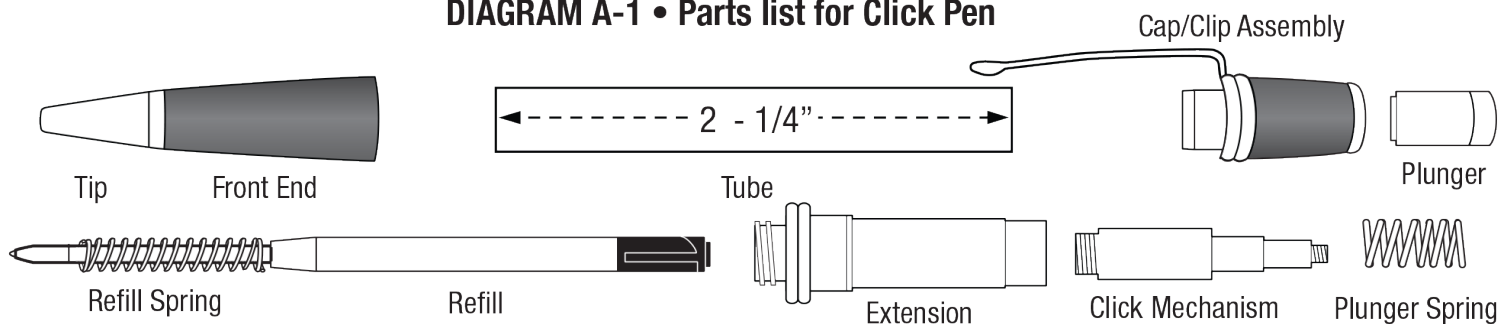

Preparing the Blank:

- Prior to cutting and gluing, always verify tube length is correct (see parts diagram). Note that tube for Gatsby Click is longer than tube for Gatsby Twist; they are not interchangeable.
- Prepare a master blank of at least 5/8" square. Cut to the length of the brass tube (add 1/16" for trimming)
- Drill a 27/64" center hole through the blank.
- Glue the tube in the blank. Spread the glue over the tube; insert the tube into the blank with a twisting motion to spread the glue evenly inside. Center the tube lengthwise inside the blank.
- When the glue dries, square the ends of the blank using a 7mm barrel trimmer with the adapter sleeve. Mount the sleeve over the shank. Trim the blank down flush with the brass tube.

DIAGRAM B • Turning the blank

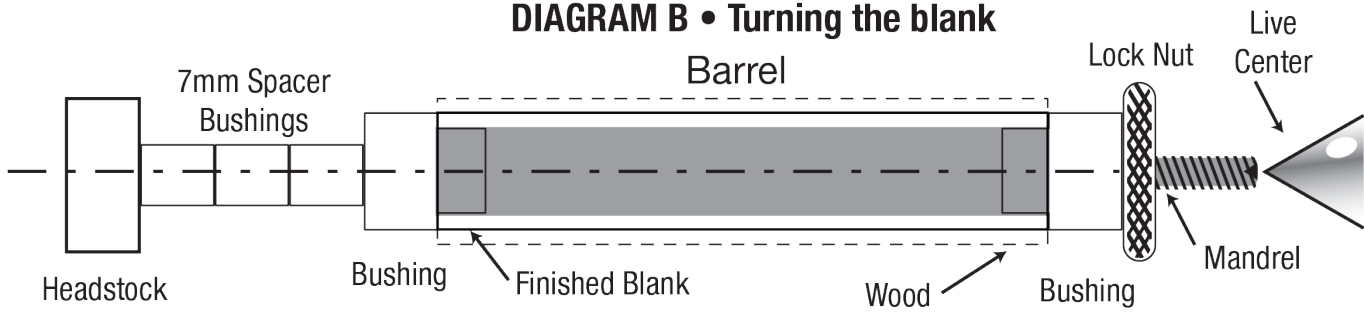

Turning the Blank

Mount spacer bushing on the mandrel. Slide the bushing, wide end in first. Insert the blank. Follow with the other bushing, narrow end in first. Mount spacer bushing to fill the space to the threads on the mandrel. Screw on the lock nut hand tight. Do not overtighten the lock nut, it may damage the mandrel. Turn the blank down, close to the bushings. Follow with abrasives until the barrel diameters are flush with the bushings. Finish with your choice of polish

Assembly

- NOTE: Line up pen parts according to DIAGRAM C-1
- Press the clip/cap assembly into the barrel. This side must be pressed first!
- Thread on the click mechanism onto the chrome end of the extension
- Press this assembly into the opposite end of the barrel
- Affix the refill spring over the refill tip. Insert the refill (black end in first) into the barrel.
- Thread on the tip assembly over the refill.
- Drop the plunger spring into the opening at the top.
- Insert the plunger and screw tight.
- The pen operates by clicking on the plunger to extract or retract the refill.

DIAGRAM C-1 • Assembly for Click Pen

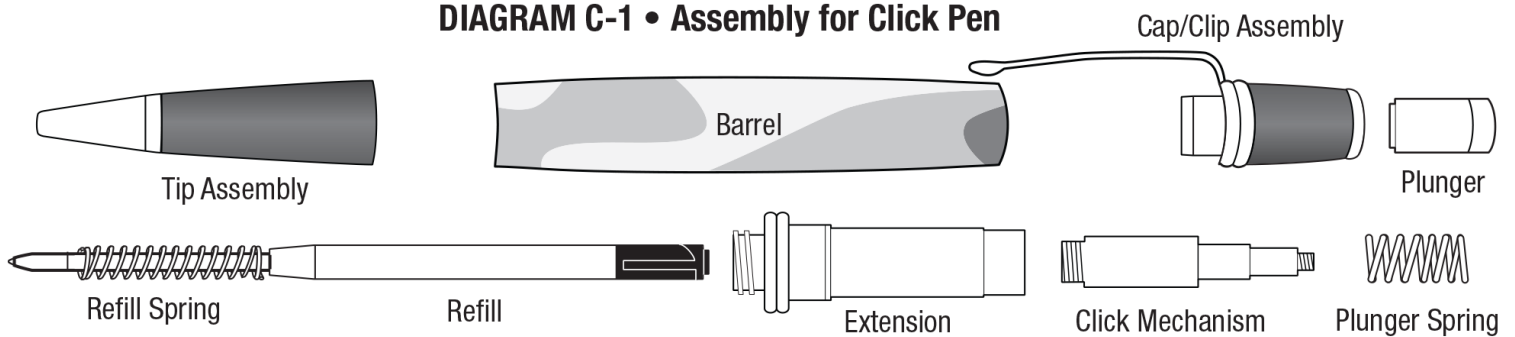

Diagram C / Bushings #PKGAPENBU

