

# The Gatsby Grande Twist Pen Kit

PKGAF24 • PKGAFGM • PKGAF24GM

## Kit Features:

- Easy to turn with a single tube
- Minimum parts - easy to assemble
- Available in multiple finishes
- A thicker version of the original Gatsby
- Overall length: 5-1/4"

## Note:

Tube diameter & tubes are not compatible with original Gatsby's 27/64" tubes/bits & bushings

## Required Accessories:

- 7mm Pen Mandrel
- Drill Bit: 3/8" #PKEXEC38
- PKGAFBU Bushing set(2 pc)
- PKTRIMKIT Barrel Trimming set (USE 3/8" SHAFT)
- Live Tailstock Center
- 2 Part Epoxy Glue or Insta Cure (Cyanoacrylate) Glue
- Pen Blank: Minimum Size - 3/4" x 2-1/2" L

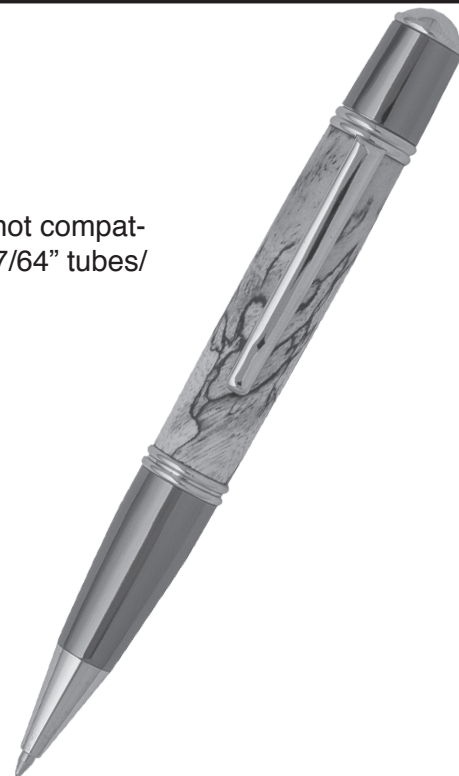
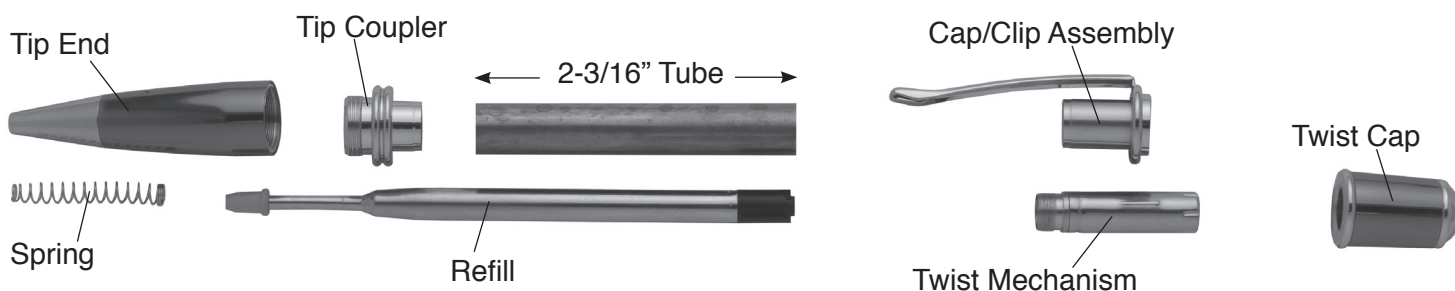
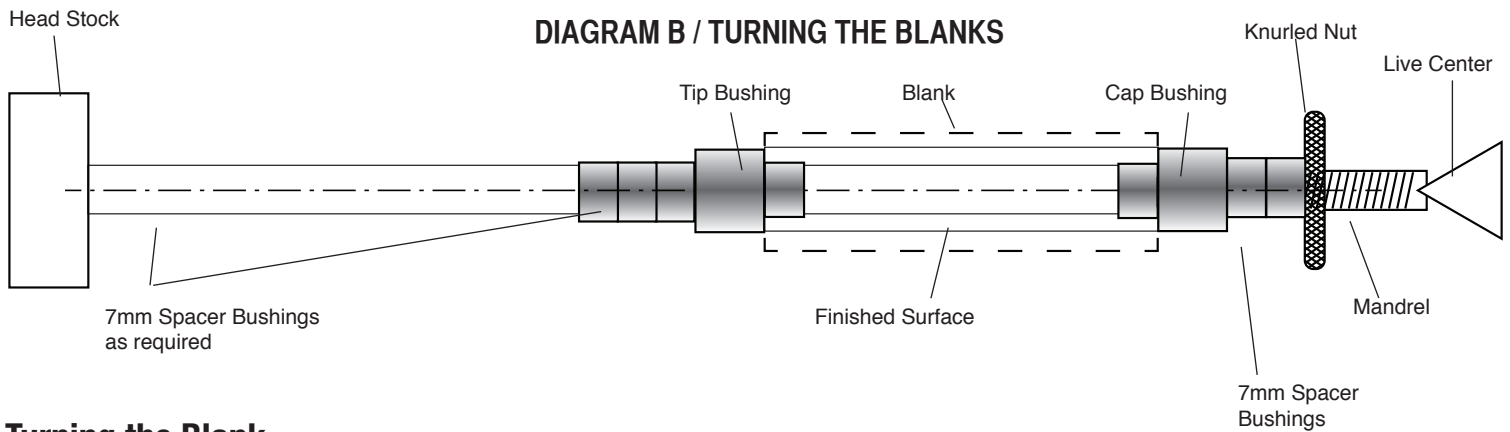

DIAGRAM A / PARTS LAYOUT



## Preparing the Blank:

- Cut a 1" blank to the length of the tube and add 1/16" for squaring off.
- Drill a 3/8" hole lengthwise through the blank.
- Spread glue over the tube, insert the tube into the blank with a twisting motion to spread the glue evenly inside. Center the tube lengthwise inside the blank.
- When the glue is dry, square the ends of the blank. Use a 7mm barrel trimmer. Take the excess material down flush with the ends of the brass tube. (do not trim beyond the length of the tube since this may interfere with operation of the mechanism and assembly).



### Turning the Blank

- Mount 7mm spacer bushings on the mandrel, followed by the tip bushing; wide end first. Insert the blank. Follow with the cap bushing; narrow end first. Mount spacer bushings to fill the space to the threads on the mandrel. Screw on the knurled nut hand tight. Bring the tailstock in snug to the mandrel and tighten the knurled nut for turning. Do not overtighten the knurled nut, it may damage the mandrel.
- Turn the blank down close to the bushings. Follow with abrasives until the barrel diameters are flush with the bushings.
- Finish with your choice of polish.

### Assembly

- Layout parts according to diagram A.
- To avoid damage to components when assembling, use vice with covered jaws or PSI #PENPRESS4.
- Press the tip coupler, plain side into either end of the barrel.
- Insert and press the cap/clip assembly into the opposite end of the barrel.
- Screw the tip end over the exposed threads of the tip coupler.
- Pull the refill tip cap off and drop the refill with the spring into the opening at the clip end.
- Screw the twist mechanism into the clip assembly threads.
- Mount and push the twist cap over the mechanism stem to bottom.
- The pen operates by twisting the cap in either direction to advance or retract the refill.

### Diagram C / Bushings #PKGAFBU

