

Fire Starter Survival Flint Kit

Kit Features:

- Use this instrument to strike fire outdoors - instead of matches
- Long lasting, multiple strikes
- Lanyard to carry and attach the striker

Required Accessories:

- Four prong drive center or similar drive
- Heavy duty, 60° degree live center
- 3/8" drill bit, item #PKEXEC-38
- 3/16" drill bit, (for lanyard)
- Mid-cure, epoxy glue



DIAGRAM A / PARTS LAYOUT

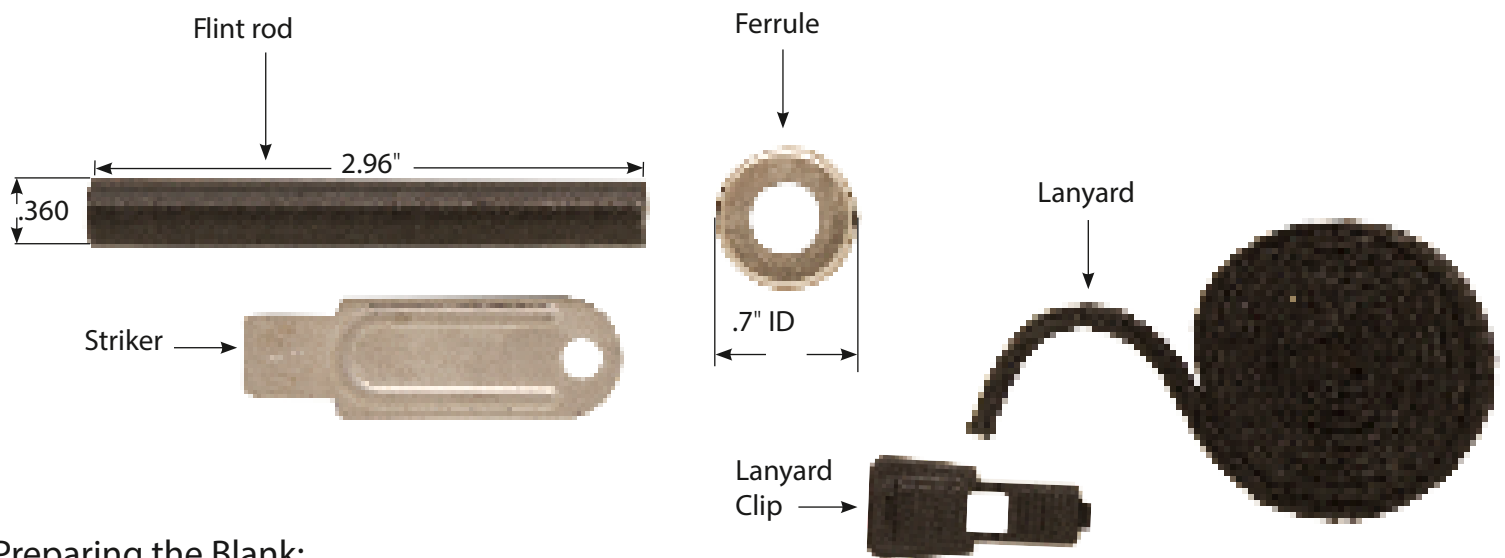

Preparing the Blank:

- Cut a blank to at least 1" square x 5" long.
- Mark the center on both ends of the blank.
- Drill a 3/8" center hole, 1" deep at the end of the blank.
- Mark 1 1/2" from the end on the opposite side of the hole.
- Drill a 3/16" centered hole through the width of the blank.
- Chamfer the hole.

DIAGRAM B / PREPARING & TURNING THE BLANK

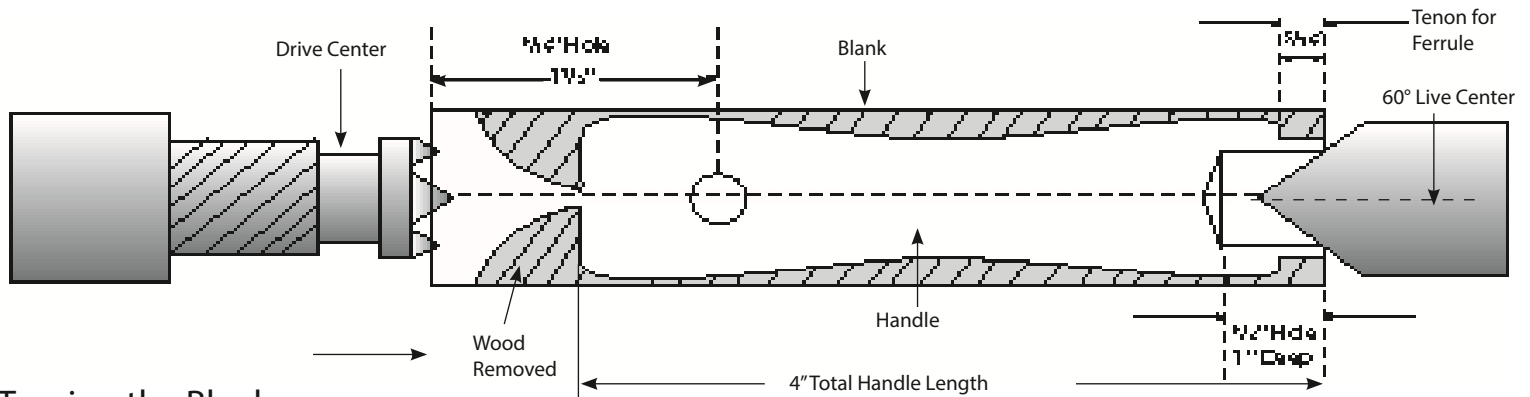

Turning the Blank

- Insert a drive center into the head stock and a 60° live center into the tail stock of the lathe.
- Lock the blank between the centers (See Dia. "B").
- Mark 5/16" on the blank over the side of the hole. Turn a tenon to match the I.D. of the ferrule about .7" ("See Dia. "B").
- Turn the blank into a handle profile. Remove wood at the drive center end. Leave a small bridge to support the handle. Sand and finish the wood.
- Part and remove the handle. Finish the end by hand off the lathe.
- We recommend using walnut, tung or other penetrating oils for finishing the handle.

Assembly

- Squeeze glue into the opening of the hole. Insert either end of the rod into hole. Let dry.
- Thread the lanyard through the hole in the handle. Attach the striker onto the lanyard. Use the lanyard clip to lock over the braided ropes. ("See Dia. "C")

DIAGRAM C

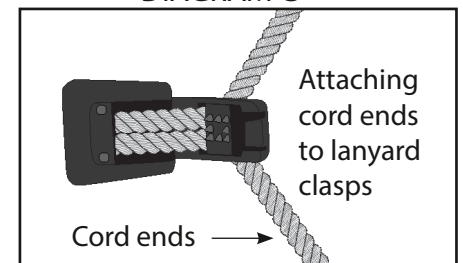

How to Use

- Position the rod so that the tip is resting on the ground and the flint is facing up.
- Press hard on the striker with your thumb sliding downward along the flint towards the kindling.
- Kindling should be close to the tip of the fire starter.
- The flint sparks are hot enough to light any fine material such as moss, dry grass, pine needles, steel wool, cloth, paper, etc.