

PKFILE Chrome-plated Diamond File Kit

KIT FEATURES

- Fine, diamond coated shaft with a groove, plus a curved and flat surface
- Use for sharpening pocketknives, fishing hooks, etc.
- Durable chrome plating
- Convenient pocket clip and closure cap
- Overall length: 4-1/2" File: 2-3/4"

REQUIRED ACCESSORIES

- 7mm pen mandrel
- 8mm drill bit **PKPARK-8MM**
- 2-pc bushing set **PKFILEBU**
- 8mm barrel trimmer
- 2-part epoxy glue or insta-cure (cyanoacrylate) glue.



Diagram A - Parts

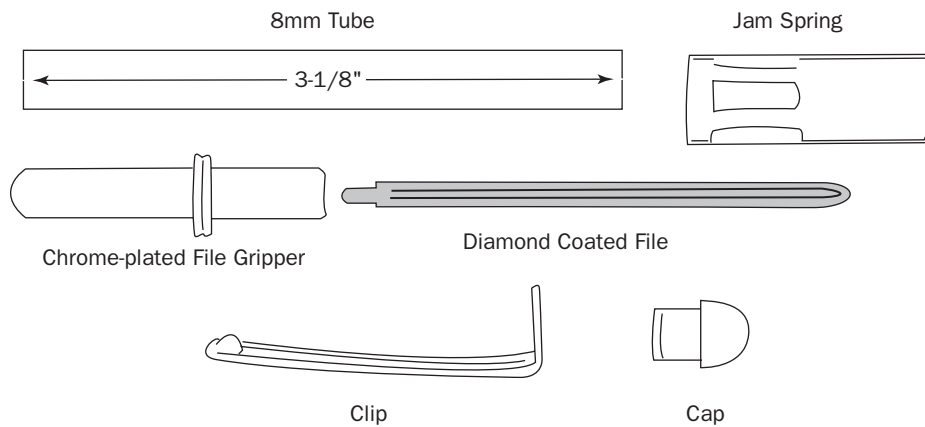

PREPARING THE BLANK

- Cut a 5/8" square blank to the brass tube (add 1/16" to the length for squaring off).
- Drill an 8mm hole lengthwise through the blank.
- Spread glue over the tube. Insert into the blank with a twisting motion to spread the glue evenly inside. Center the tube lengthwise in the blank.
- When dry, use an 8mm barrel trimmer to square the ends of the blank. Take the wood down flush to the brass tube.

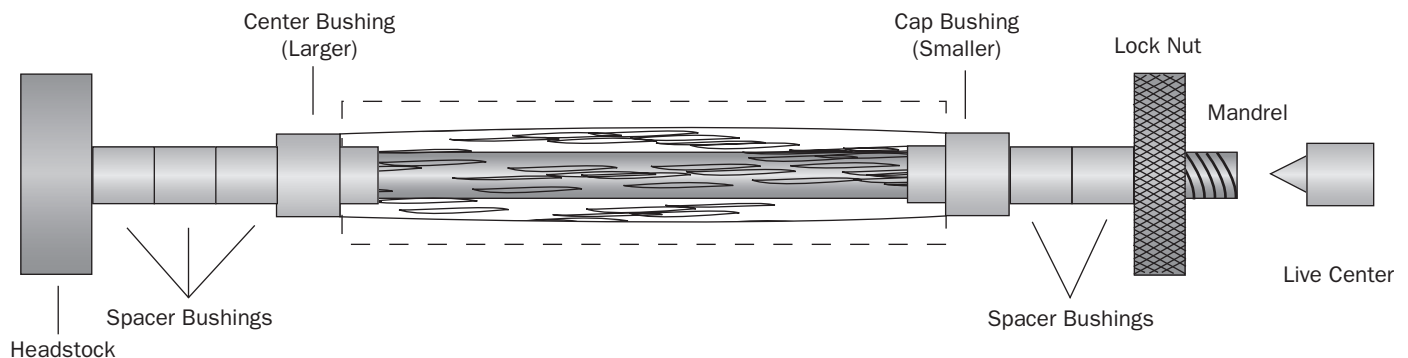

Diagram B - Turning the Blank

TURNING THE BLANK

Place spacer bushings on the mandrel shaft, if needed. Insert the center bushing, wide end on first. Follow with the blank, then the cap bushing narrow end on first. Add spacer bushings to close the space to the threads. Thread on the knurled nut hand tight. Bring the tailstock over to engage with the mandrel shaft. Lock in place. Tighten the lock nut (do not over-tighten, it may damage the mandrel). Turn the wood down in a rounded profile between the end bushings using lathe chisels and progressive grades of abrasive. Finish the wood with your choice of polish.

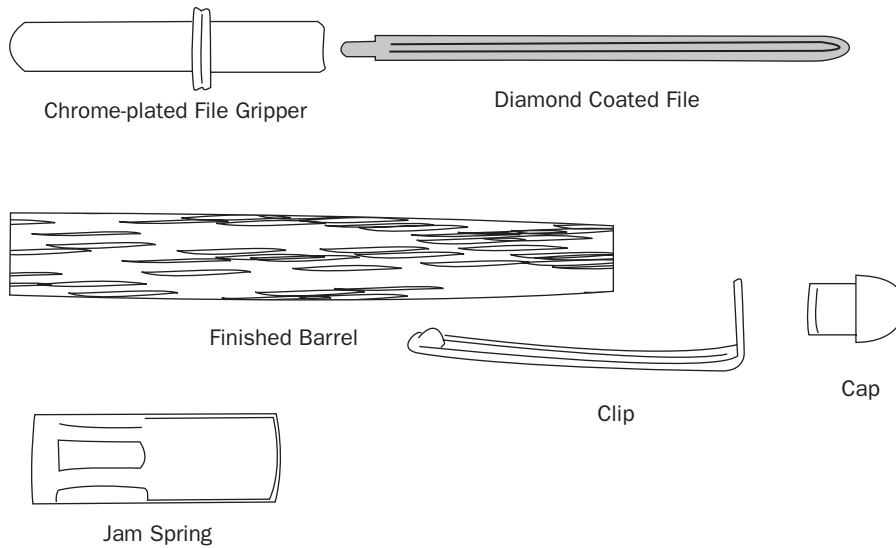

Diagram C - Assembly

ASSEMBLY

- Line up finished parts according to Diagram 'C'.
- Insert the cap into the clip hole. Press the assembly into the upper, smaller diameter of the barrel.
- Insert the spring, solid end in first into the opening at the opposite end.
- Squeeze a drop of glue into the hole of the gripper. Insert the polished end of the file, let dry.
- Insert the file into the barrel.
- To use this tool, just pull the file assembly out, attach the gripper into the barrel. Use the barrel as a handle when sharpening objects.

