

Executive Twist Pen and Pencil Kits

Kit Features:

- Golden plated with epoxy coating.
- Designed matching pen and pencil set.
- Pen features twist mechanism w/Parker® type ball point refill #PK-PARK-R5
- Pencil features twist mechanism w/heavy 7mm lead
- Overall Pen & pencil Length: 5-1/8"

Required Accessories:

- 7mm Pen Mandrel
- 2-pc. pen bushing set #PKEXEC-BU
- 3/8" Drill Bit: #PKEXEC-3/8
- #PKTRIMKIT (optional)
- 2 Part Epoxy Glue or Insta Cure (Cyanoacrylate) Glue

Preparing the Blank:

- Cut a 3/4" to 5/8" square blank to the length of the brass tube (add 1/16" for squaring off)
- Drill a 3/8" diameter center hole, lengthwise through the blank.
- Spread glue over the tube. Insert the tube into the blank with a twisting motion to spread the glue evenly inside. Center the tube lengthwise inside the blank.
- When the glue dries, square the ends of the blank. Use a 3/8" trimmer to trim the wood down flush to the end of the brass tube.

Turning the Blank:

- Slip three spacer bushings on your mandrel. Follow with the cap bushing (wide diameter first).
- Slide on the blank, then place the tip bushing (narrow diameter first) on the mandrel.
- Thread on the lock nut hand tight. Bring the tail stock snug with the mandrel. Do not overtighten, it could damage the mandrel.
- Using a lathe chisel, turn the blank down flush with the bushings.
- Finish the blank with gradual higher grits of sand paper and your choice of polish and waxes.

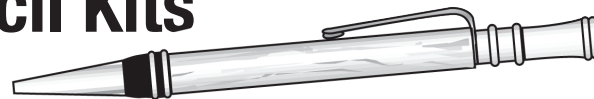

Pen Parts

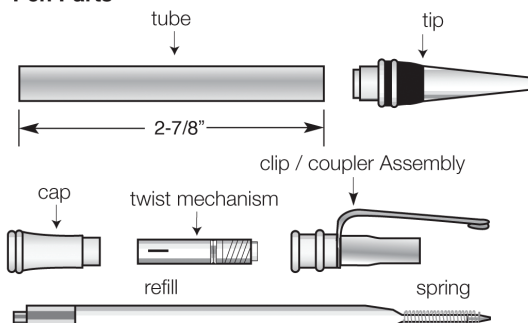

Pencil Parts

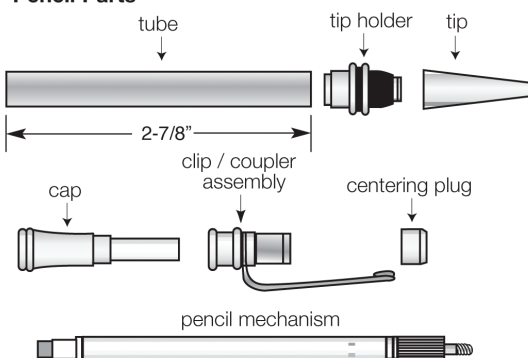
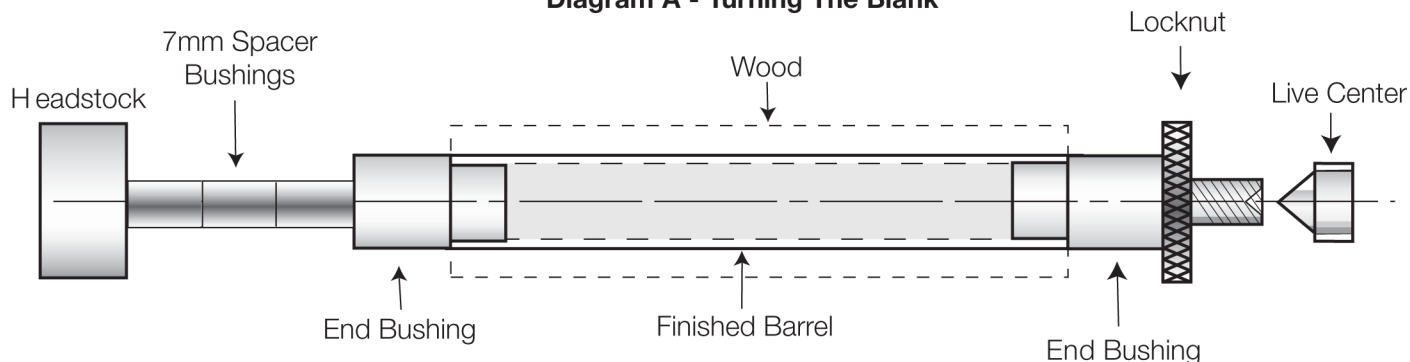
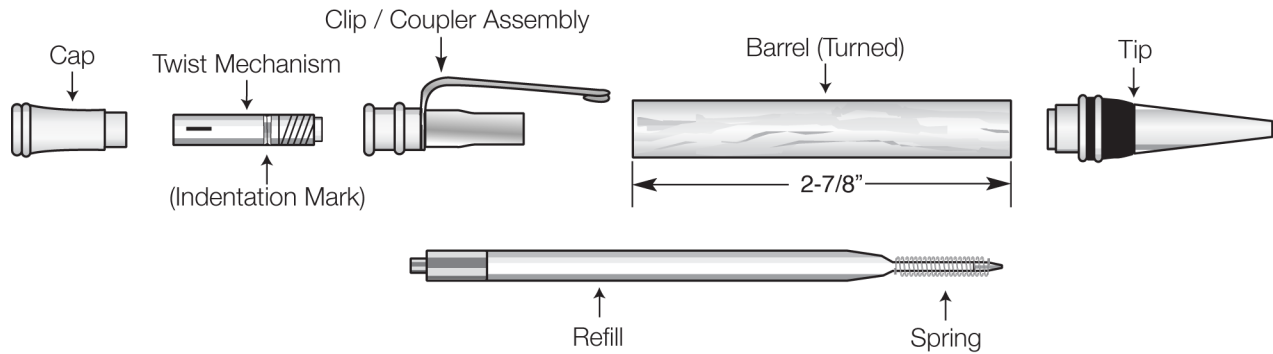

Diagram A - Turning The Blank



Pen Assembly



Pen Assembly:

- Line up finished parts according to the diagram above.
- Press clip/coupler assembly into barrel.
- Press the tip assembly carefully into the other end of the barrel.
- Insert the refill with the spring into the barrel.
- Screw the twist mechanism into the coupler until it stops.
- Push cap onto twist mechanism by hand.
- Pen operates by twisting the cap to extend or retract the refill.

Pencil Assembly

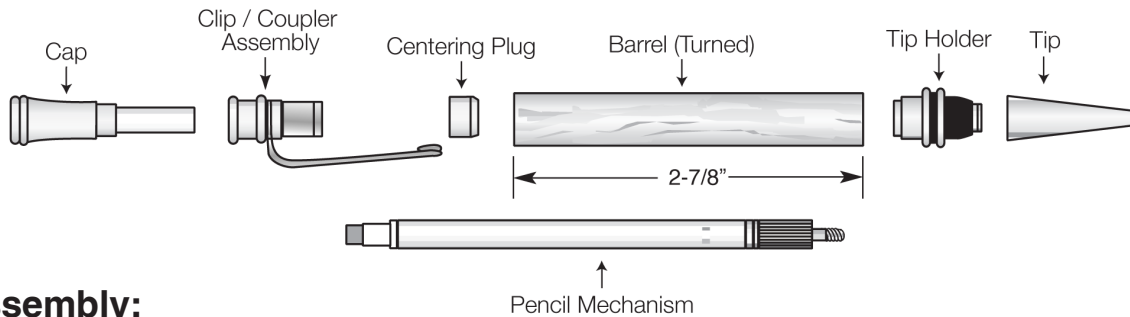

Pencil Assembly:

- Line up finished parts according to the diagram above.
- Insert centering plug, recessed end first into the barrel.
- The centering plug must go into the tube at least 3/4". To do this you will need a 5/16" bolt and nut. (Thread the nut as shown in picture below. When assembling, press the centering plug into the tube, as described in the instructions. Then place the narrow end of the bolt against the centering plug and press until the nut meets the end of the barrel.
- Press clip/coupler assembly in front of the centering plug.
- Press the tip holder into the other end of the barrel.
- Insert the pencil mechanism into the barrel with the threaded stud extending through the hole in the tip holder.
- Turn the cap to extend to retract the lead as needed.

Pencil Assembly:

- Remove the cap then unscrew the tip end and pull the pencil mechanism out through the clip/coupler assembly.
- Pull out the eraser and holder together. Remove a new lead from the cartridge and replace the eraser and holder.
- Twist the mechanism forward until the gripper and pilot extend out. Retract until gripper is flush with the thread.
- Gently push the new lead into the gripper opening. Twist the mechanism back until the lead is completely inside.
- Slide the mechanism back tightly.
- Place the cap over the top. The pencil is ready to operate.

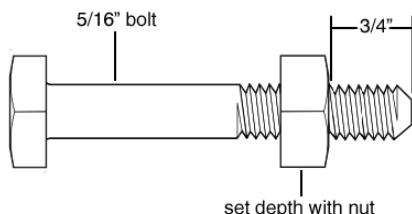

Bushings - #PKEXEC-BU

