

The “Classic” Elite Petite Pen Kit 10mm tubes

PKELP24 • PKELPCH • PKELPGM

Kit Features:

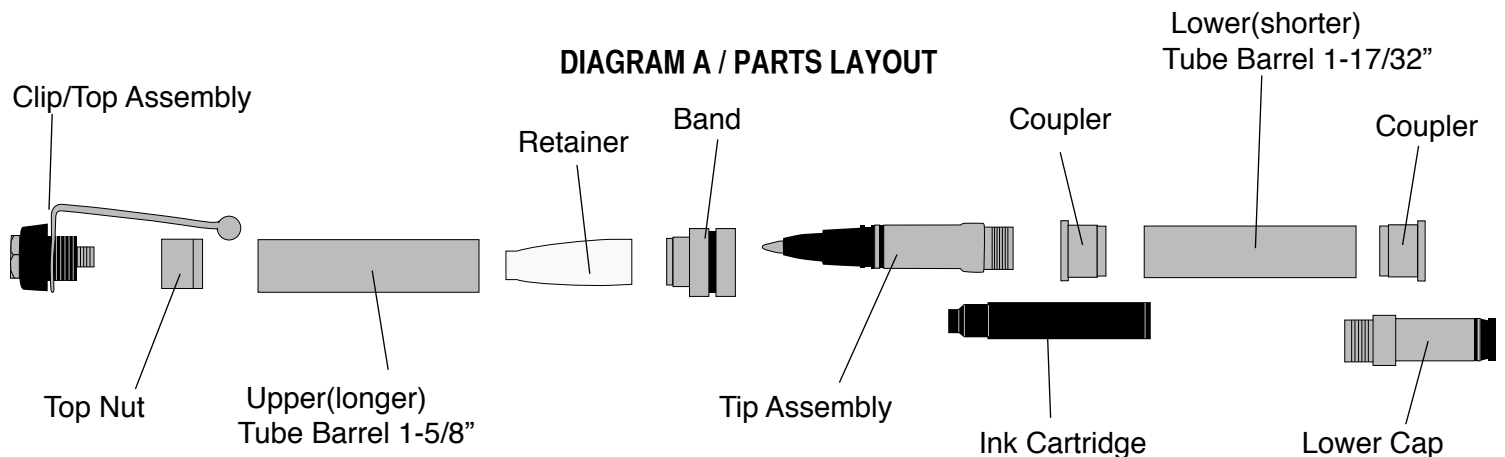
- Superior Writing, Use real fountain pen cartridge
- Easy to turn with straight cuts
- Cartridge #PK10-FPR
- Posts front and back
- Minimum parts - easy to assemble
- Available in multiple finishes

Required Accessories:

- 7mm Pen Mandrel
- Drill Bit 10mm #PK10-10
- PKPAR10-B2 Bushing set(3 pc)
- PKTRIMKIT Barrel Trimming set Use 10mm Shaft
- Live Tailstock Center
- 2 Part Epoxy Glue or Insta Cure (Cyanoacrylate) Glue
- Total Pen Blank: Minimum Size- 3-1/2” x 5/8” (overall)
- Click retainer assembly tool #PKRETOOL (optional)

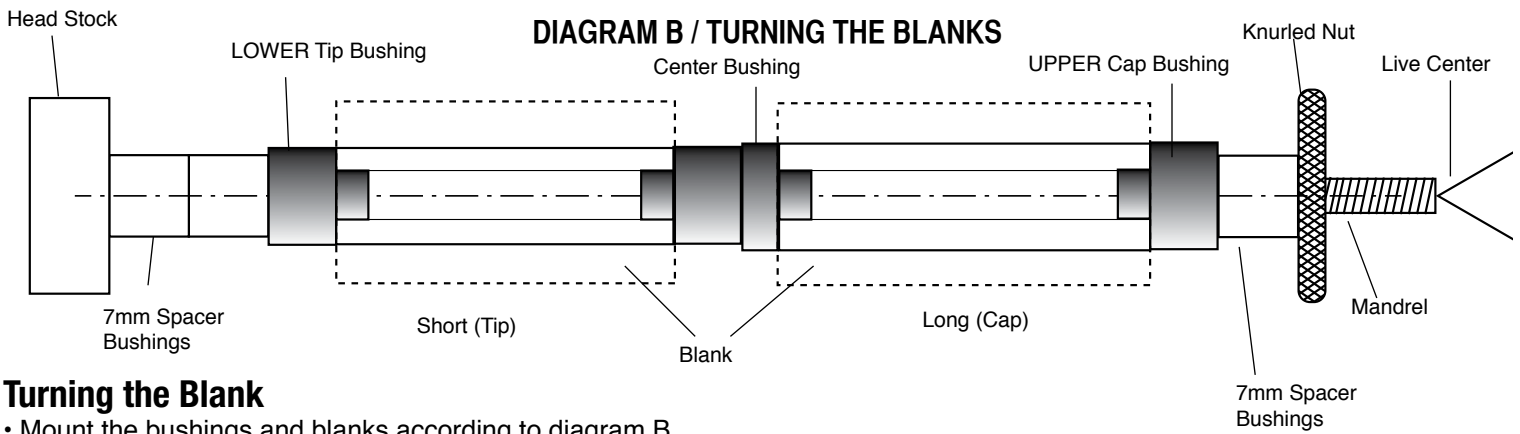


DIAGRAM A / PARTS LAYOUT



Preparing the Blank:

- Cut 2 blanks to the length of the tubes and add 1/16” for squaring off.
- Drill 10mm holes lengthwise through the blanks.
- Spread glue over the tubes, insert the blank with a twisting motion to spread the glue evenly inside. Center the tubes lengthwise inside the blanks.
- When the glue is dry, square the ends of the blanks. Use 10mm barrel trimmer from the barrel trimming system. Take the excess material down flush with the ends of the brass tube. (do not trim beyond the length of the tube since this may interfere with operation of the mechanism and assembly). Use a barrel trimmer to clean the inside of the tube.



Turning the Blank

- Mount the bushings and blanks according to diagram B.
- Thread on the knurled nut and hand tighten to hold all components in place.
- Slide the tailstock up snugly against the mandrel shaft inserting the live center point into the mandrel dimple, lock in place.
- Hand tighten the quill adjustment to firm up the mandrel. (DO NOT overtighten, it could damage the mandrel.)
- Using sharp tools, turn the blank down close to the bushing diameter. Turn the barrel (straight or to a profile of your choice)
- Sand the blank down to be flush with the bushings gradually increasing the sandpaper grits.
- Finish the barrel with your choice of polish. Allow sufficient time for the polish to cure. Refer to polish instructions.

Assembly

- Layout finished parts according to diagram A.
- Press the top nut, recess end first into either end of the upper barrel (longer).
- Insert the retainer, narrow end first into the the opposite end of the upper barrel.
- Insert and press the band, extended end first. Follow the retainer.
- **IMPORTANT:** Retainer must be inserted into tube before band is inserted since reatianer will not fit through the band.
- Insert the reatainer tool, push in to bite into the retainer turn a few turns to stay screwed in.
- Screw cap/top assembly into top nut.
- Press each coupler, recess end in first into each end of the lower barrel (shorter).
- Insert and push in the ink cartridge into the back end of the tip assembly to break the seal. Squeeze cartridge lightly to advance ink forward.
- Screw the tip assembly into either end of the lower barrel.
- Screw the lower cap into the opposite end of the lower barrel.

Diagram C / Bushings #PKPAR10-B2

