

CIVIL WAR TWIST PEN KIT

#PKCWPEN #PKCWPEGM #PKCWPEMS

KIT FEATURES

- Chrome, Gun Metal, Satin plated brass parts.
- Authentic Bullet and Musket design components
- Smooth cap twist operation
- Pen uses a Parker® style ball point refill #PK-PARKRS
- Includes Civil War information pamphlet.
- Overall length (each) 4-7/8"

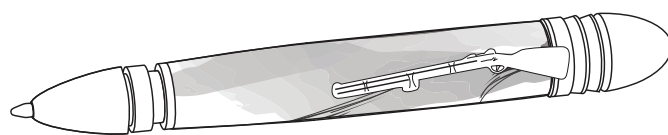

REQUIRED ACCESSORIES:

- 7 mm, mandrel
- 2 piece bushing set #PKCWPEMBU
- 3/8" drill bit #PKEXEC-3/8
- Universal barrel trimming system #PKSQUARE (optional)
- 2 part epoxy glue, polyurethane glue or insta cure (cyanoacrylate) .
- Live Center

PREPARING THE BLANK

- Cut 3/4" or larger square blank to the length of the brass tube (add 1/16" for squaring off).
- Drill a 3/8" center hole lengthwise through the blank.
- Spread the glue over the tube. Insert the tube into the blank with a twisting motion to spread the glue evenly inside. Center the tube lengthwise in the blank.
- When glue dries square the ends of the blank. Use the 3/8" of the barrel trimmer system to square the ends. Take the wood down flush to the brass tube. Do not trim beyond the length of the brass tube or leave excess glue inside the tube, since this may interfere with operation of the mechanism and assembly. Clean the inside of the tube of glue.

DIAGRAM A / Parts list

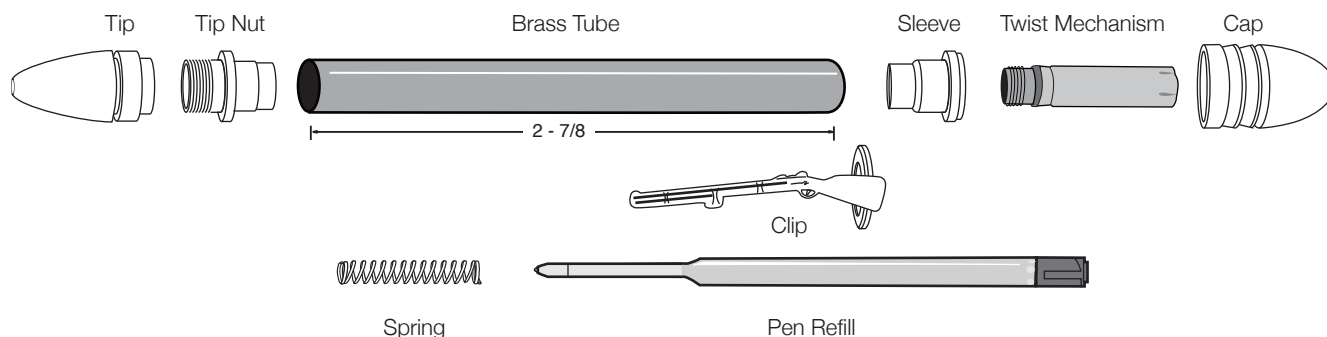

TURNING THE BLANK

- Place three or four standard 7mm bushings onto the mandrel, followed by the cap bushing (larger) - wide end first, then the wood blank and lastly the tip bushing (smaller) narrow end first. Use additional spacer bushings to fill the space on the shaft up to the threads.
- Thread on the knurled nut and hand tighten to hold all items in place.
- Slide the tail stock snug to the mandrel shaft, (do not over tighten, it could damage the mandrel). Lock in place.
- Turn the wood down, flush with the bushings using lathe tools and gradual higher grits of sandpaper.
- Finish the wood with friction polish or use PSI clear hi-gloss project finish #HGPF off the lathe for a brilliant finish.

DIAGRAM B / Turning the Blank

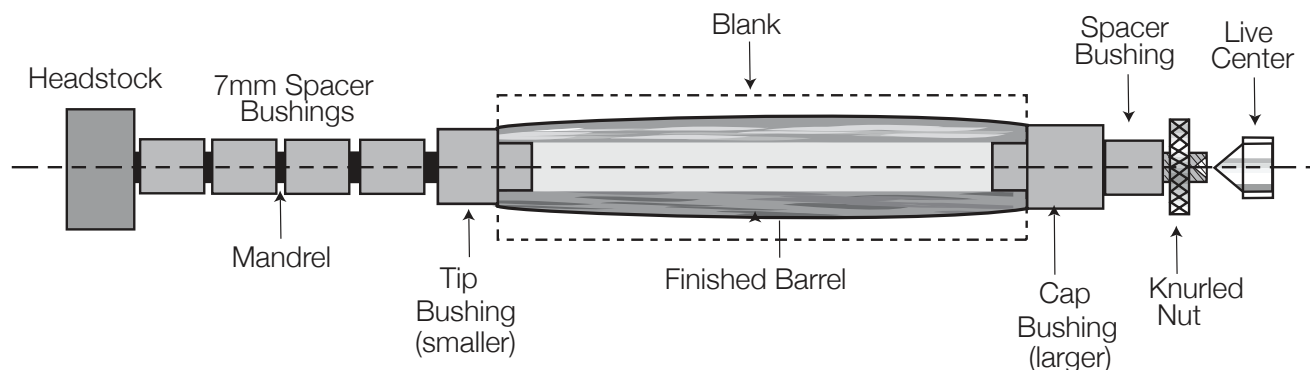
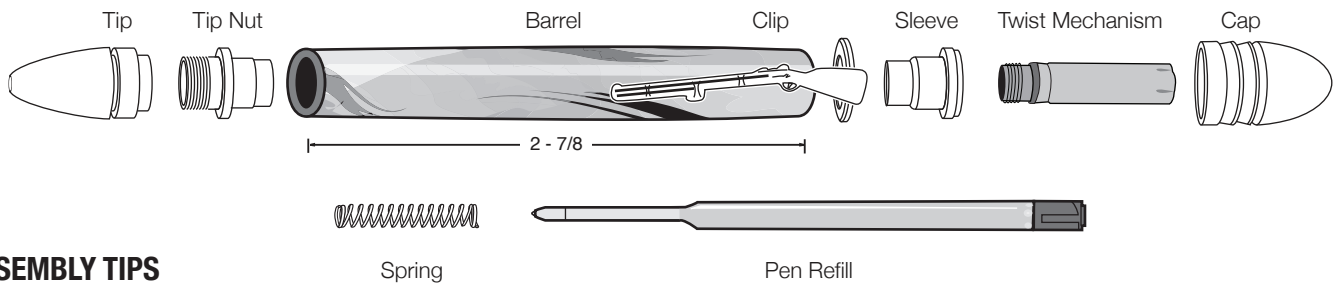

DIAGRAM C / Pen assembly



ASSEMBLY TIPS

- Line up finished parts according to Diagram C.
- To press parts in, use a pen vise or a vice with covered jaws. Press parts slowly to avoid scratching and damaging the gold plated parts.

PEN ASSEMBLY

- Insert the tip nut, recessed end in first, into the narrow end (tip) of the barrel, and press to the shoulder.
- Insert the sleeve through the clip washer. Press the narrow end of the sleeve into the opposite end of the barrel.
- Insert the twist mechanism, brass end first into the opening at the sleeve. Thread the mechanism tightly until it stops. Test that the mechanism turns freely back and forth.
- Insert the refill with the spring over it, black end into the opening at the tip end. Thread the tip over the nut.
- Insert the cap assembly over the exposed end of the mechanism.
- The pen operates by twisting the cap to extend or retract the refill
- To replace refill, unscrew tip..

DIAGRAM D • #PKCWPENBU

