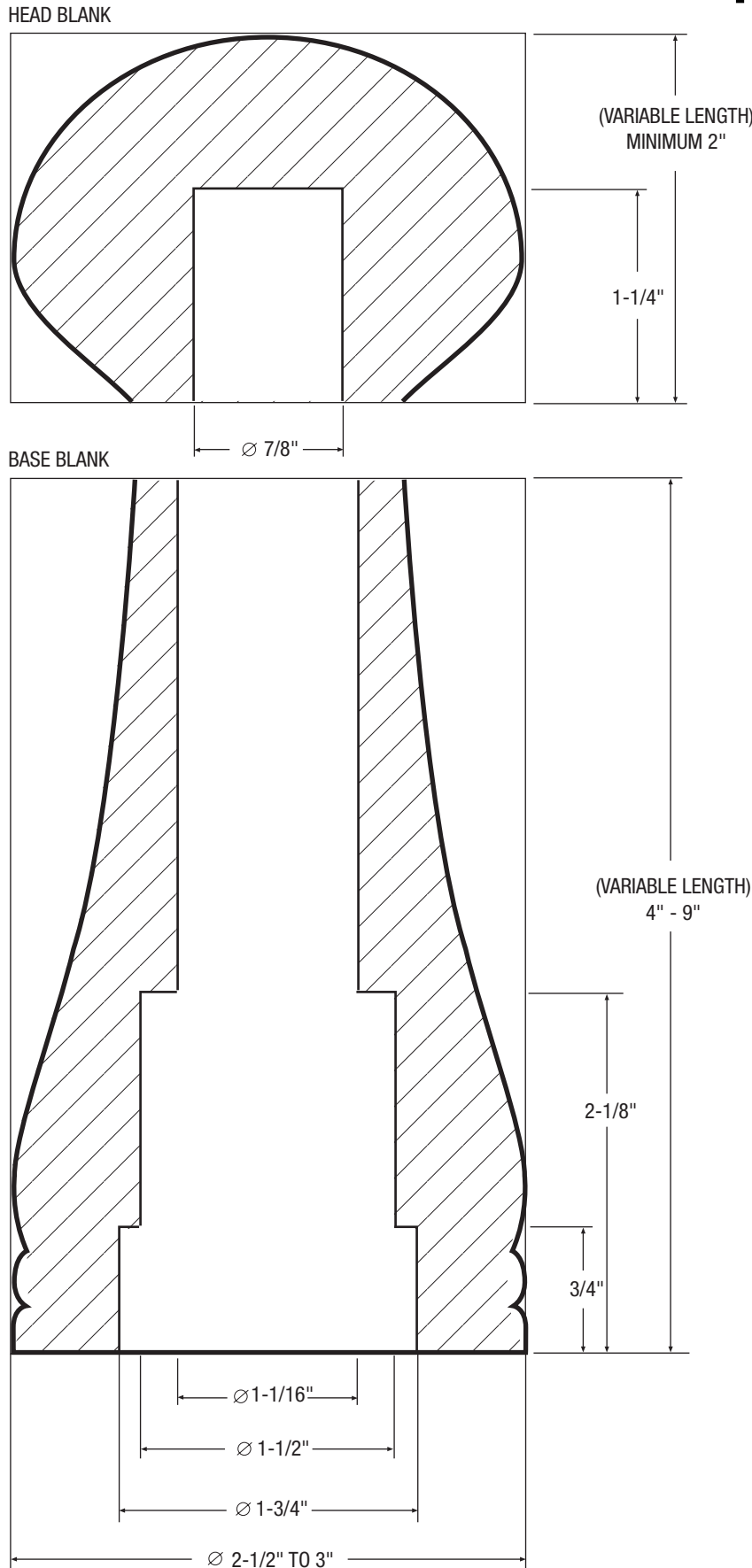

Diagram A - Boring the Blanks



PKCRUSHS Instructions

Crush Grind with Stem



Required Accessories

- **FB78** 7/8" Forstner bit
- **FB1-116** 1-1/6" Forstner bit
- **FB150** 1-1/2" Forstner bit
- **FB134** 1-3/4" Forstner bit
- **FEX** Forstner bit extender

Required Wood

- *Base blank* - 4" (minimum) to 9" (maximum) length by 2-1/2" to 3" square depending on your design length.
- *Head blank* - 2" square or more.

Boring the Blanks (see Diagram A)

- *Base blank* - Locate the center of the blank and bore sequential holes:
 1. Bore a 1-3/4" hole to 3/4" deep
 2. Bore a 1-1/2" hole 2-1/8" total depth
 3. Bore a 1-1/16" hole through (use drill bit extender)
- *Head blank* - Locate the center of the blank and bore a 7/8" hole to 1-1/4" deep

Turning the Blanks

- *Base Blank* - Use a jam chuck to 1-1/2" diameter. Insert into the base blank and mount over the lathe.
- Support opposite end using a large live center. (See Diagram B)
- Turn a profile, sand, and finish the wood.
- *Head Blank* - Use a jam chuck 7/8" diameter.
- Insert into head blank.
- Mount over the lathe.
- Support with live center.
- Turn a profile and finish the wood.

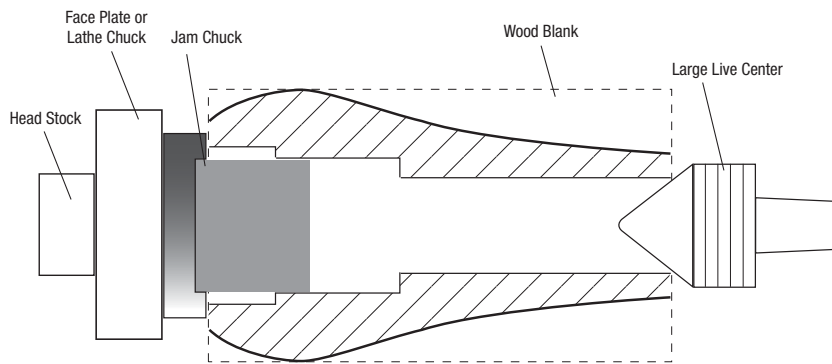
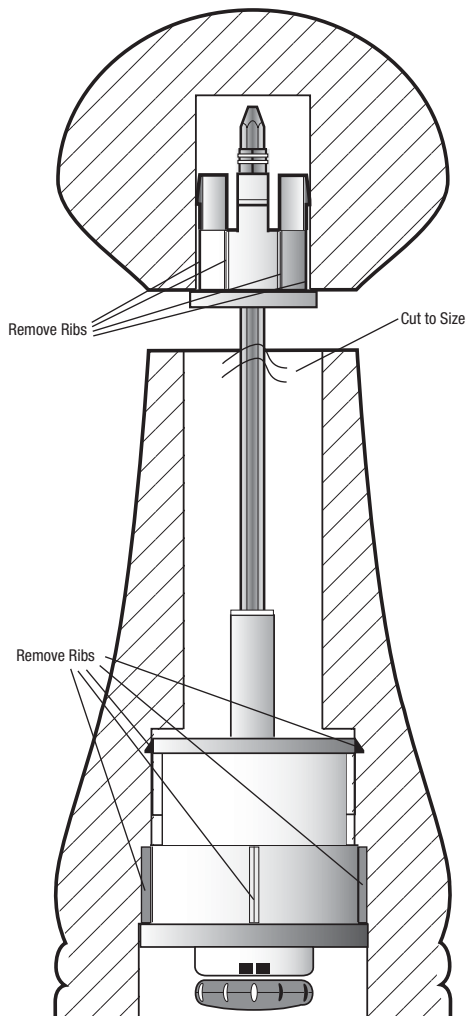
Diagram B - Mounting Base Blank**Diagram C - Assembly****Assembly (see Diagram C)**

- **NOTE:** The mechanism is designed to fit in metric holes. In order to fit in standard holes, some modifications to the mechanisms are necessary.
- Remove the 6 ribs over the surface of the grinding mechanism and the knob mechanism.
- Remove the edge of the clips (if necessary).
- Trim the stem to adjust to the length of the wooden base you have chosen.
- Insert mechanisms prior to gluing to check fit, centering, and stem length.
- Use glue carefully (avoid any moving parts) over surface of the mechanism. Insert and press the base mechanism firmly into the 1-1/2" hole.
- Glue over the outer surface of the top mechanism. Insert and press into the head blank.
- When glue dries, insert the head over the stem. The stem should penetrate the sleeve in the top mechanism. The bottom edge of the mechanism should go into the 1-1/16" hole.
- To adjust the coarseness of the grind, just twist the gray knob in or out.