

# 30 Cal. Letter Opener/Magnifier Kit

Letter Openers: PKCP3500 • PKCP3510 • PKCP3520

Magnifiers: PKCP3600 • PKCP3610 • PKCP3620

## Kit Features:

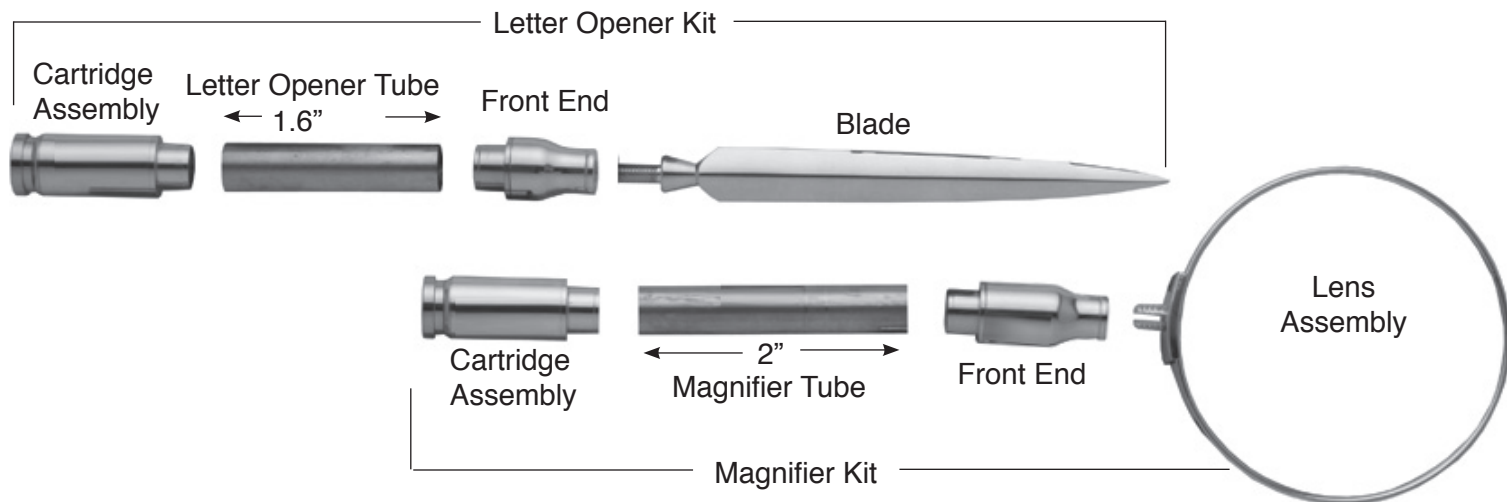
- Easy to turn with straight tube
- Minimum parts - easy to assemble
- Available in multiple finishes
- Matches all other PSI Bullet Cartridge pen kits to make sets
- Uses same accessories (drill bit & bushings) as other 3/8" tube Bullet Cartridge Pen Kits

## Required Accessories:

- 7mm Pen Mandrel
- Drill Bit: 3/8" #PK-EXEC38
- #PKCP3000BU Bushing set(2pc)
- #PKTRIMKIT Barrel Trimming set (USE 3/8" SHAFT)
- Live Tailstock Center
- 2 Part Epoxy Glue or Insta Cure (Cyanoacrylate) Glue
- Blank: Minimum Size - 5/8" x 2"

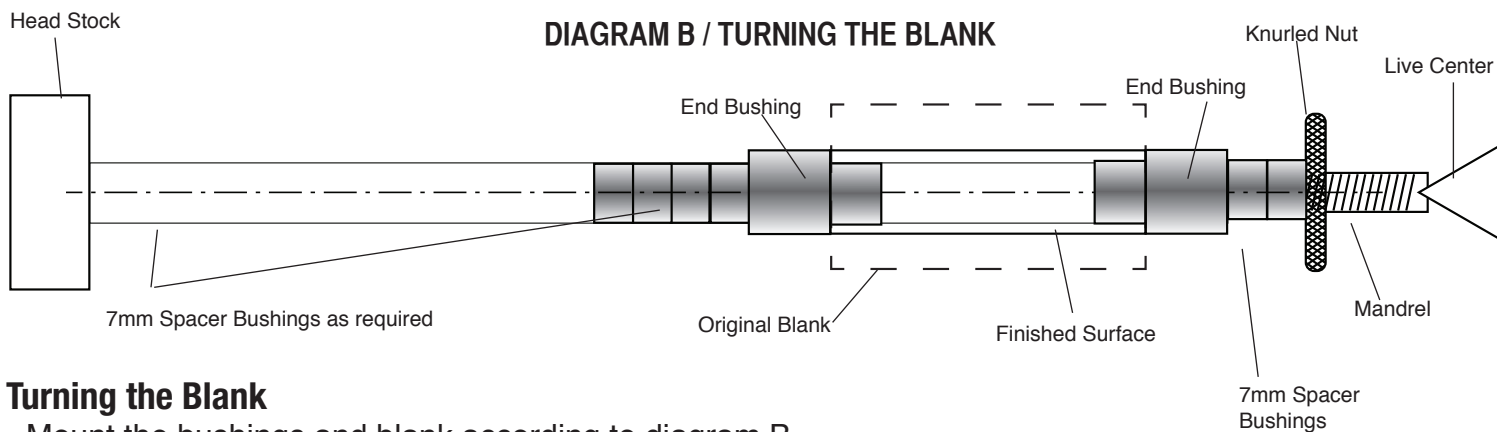


DIAGRAM A / PARTS LAYOUT



## Preparing the Blanks:

- Cut a blank to the length of the tube(s) and add 1/16" for squaring off.
- Drill 3/8" hole lengthwise through the blank.
- Spread glue over the tube, insert the blank with a twisting motion to spread the glue evenly inside.
- Center the tube lengthwise inside the blank.
- When the glue is dry, square the ends of the blank. You can use a 3/8" barrel trimmer to take the excess material down flush with the ends of the brass tube.



### Turning the Blank

- Mount the bushings and blank according to diagram B.
- Thread on the knurled nut and hand tighten to hold all components in place.
- Slide the tailstock up snugly against the mandrel shaft inserting the live center point into the mandrel dimple, lock in place.
- Hand tighten the quill adjustment to firm up the mandrel. (DO NOT over tighten, it could damage the mandrel.)
- Using sharp tools, turn the blank down close to the bushing diameter. Turn the barrel (straight or to a profile of your choice)
- Sand the blank down to be flush with the bushings gradually increasing the sandpaper grits.
- Finish the barrel with your choice of polish. Allow sufficient time for the polish to cure. Refer to polish instructions.

**NOTE: Please do not press the front end of this kit with the tip removed. If you do so the parts will not assemble properly and you will void our warranty**

### Assembly

- Layout parts according to diagram A
- Press the cartridge assembly into either end of the barrel for both magnifier and opener.
- Press the front end into the opposite end for both magnifier and opener.
- Screw the blade into the front end, or Screw the Magnifier rim into the front end.

### Diagram C / Bushings #PKCP3000BU

