

# 30 CALIBER BULLET CARTRIDGE TWIST PEN KIT

## KIT FEATURES

- Replicates an actual 30-caliber shell casing.
- Tip plated in rose gold to simulate an actual copper bullet.
- Twist type mechanism.
- Most components pre-assembled.
- Uses Parker™ style refill (gel compatible).
- Overall length: 5-1/4"
- Available in a variety of finishes.

## REQUIRED ACCESSORIES:

- 7mm Pen Mandrel
- 3/8" Drill Bit -#PKEXEC -3/8
- 2 pc Bushing Set -#PKCP3000BU
- Universal Barrel Trimmer system #PKTRIMKIT (Use 3/8" shaft)
- 2-part epoxy glue or insta-cure (cyano acrylate) glue
- Live tailstock center
- Blank minimum size: 5/8" x 2-1/4"

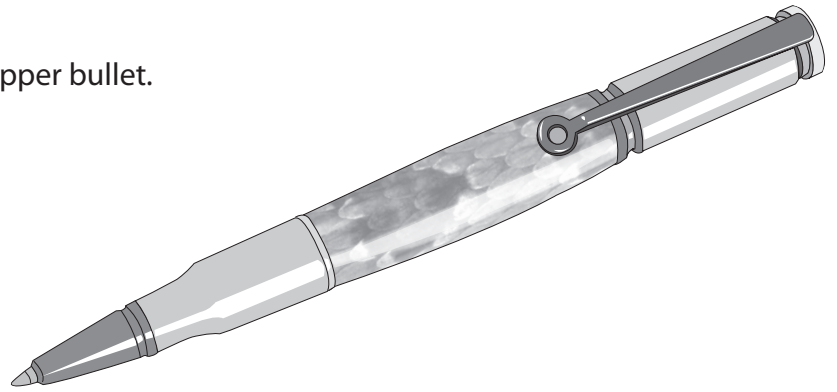

## PREPARING THE BLANK

- Cut 5/8" or larger square blank to the size of the brass tube. Add 1/16" to each end for squaring off.
- Drill an 3/8" hole through the center of the blank.
- Apply glue to the tube and insert it into the blank with a twisting motion to spread the glue evenly. Center the tube within the blank and allow to dry.
- Use a barrel trimmer (PKTRIMKIT) to square the ends of the blank to the brass tube. Do not trim beyond the length of the tube since this may interfere with operation of the mechanism and assembly. Use a barrel trimmer to clean the inside of the tube.

## DIAGRAM A / Parts list

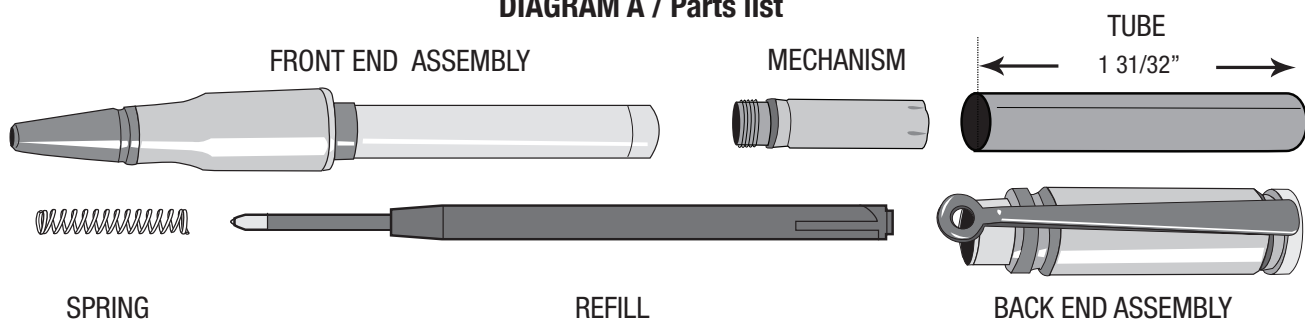

## TURNING THE BLANK

- Place spacer bushings on the mandrel. Place one end bushing on, followed by the prepared blank.
- Insert the second end bushing. Follow with additional spacer bushings as needed.
- Thread the knurled nut hand tight onto the mandrel. Do not overtighten, it could damage the mandrel.
- Bring tailstock snug to the mandrel and lock it into place. Tighten the knurled nut for turning.
- Using sharp tools, turn the blank down and sand it to the size of the end bushings.
- Finish the blank with your choice of polish.

## DIAGRAM B / Turning the blank

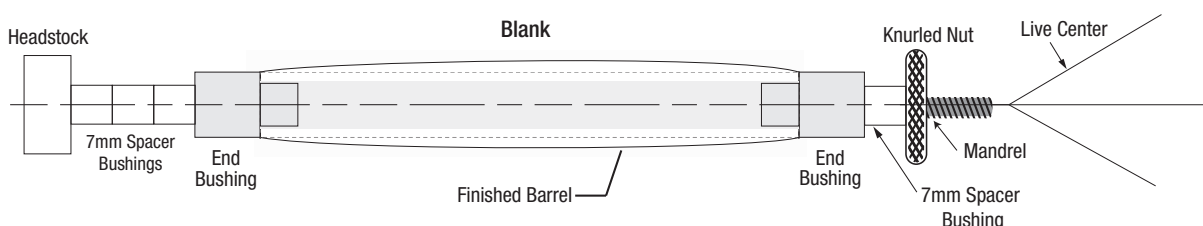

**DIAGRAM C / Pen assembly**

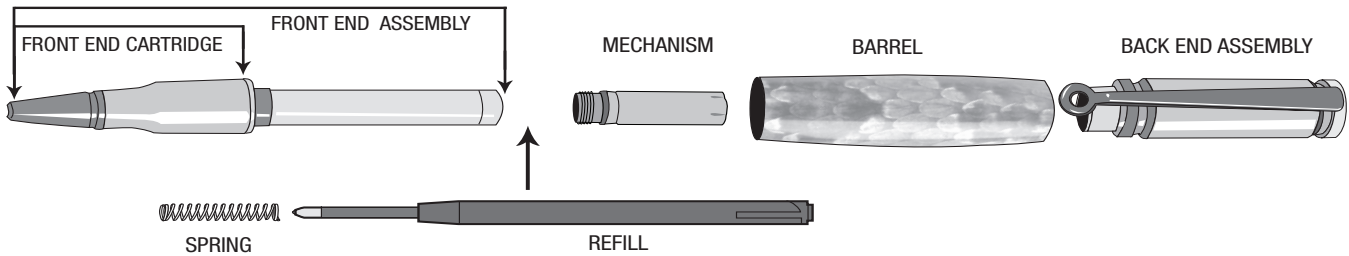

*NOTE: Please do not press the front end of this kit with the tip removed. If you do so the parts will not assemble properly and you will void our warranty*

**PEN ASSEMBLY**

- Line up the pen parts according to DIAGRAM C.
- Remove the refill protector.
- Place the refill spring over the tip end of the refill.
- Insert the refill into the front end of the assembly.
- Thread the mechanism in the front end assembly behind the refill.
- Press the barrel into the connector at the back end assembly.
- Insert the front assembly with mechanism installed into the barrel; push in until barrel is flush to the front end cartridge. The back end assembly will firmly engage the mechanism.
- The pen operates by twisting the front end cartridge to advance or retract the refill.
- To replace the refill - unscrew the barrel from the front end cartridge (mechanism will remain in back end assembly).

**DIAGRAM D • #PKCP3000BU**

