

Cortona Twist Pen Kit

Kit Features:

- Easy to Turn With Straight Tubes
- Minimal Parts-easy to assemble
- Available in multiple finishes
- Overall Length: 5-1/8" to 5-5/16" (Stylus version)
- Replacement stylus tips available PKCORTIP (4 Pack)

Required Accessories:

- 7mm Pen Mandrel
- Drill Bit: PKPARK-8MM
- Bushing Set(2 pc): PKCORBU
- Barrel Trimming set: PKTRIM8 or 8mm sleeve from PKTRIMSET
- Live Tailstock or Mandrel Saver
- 2 part Epoxy or Thick CA (Cyanoacrylate) Glue
- Pen Blank Minimum Size: 3-1/8"



DIAGRAM A / PARTS LAYOUT

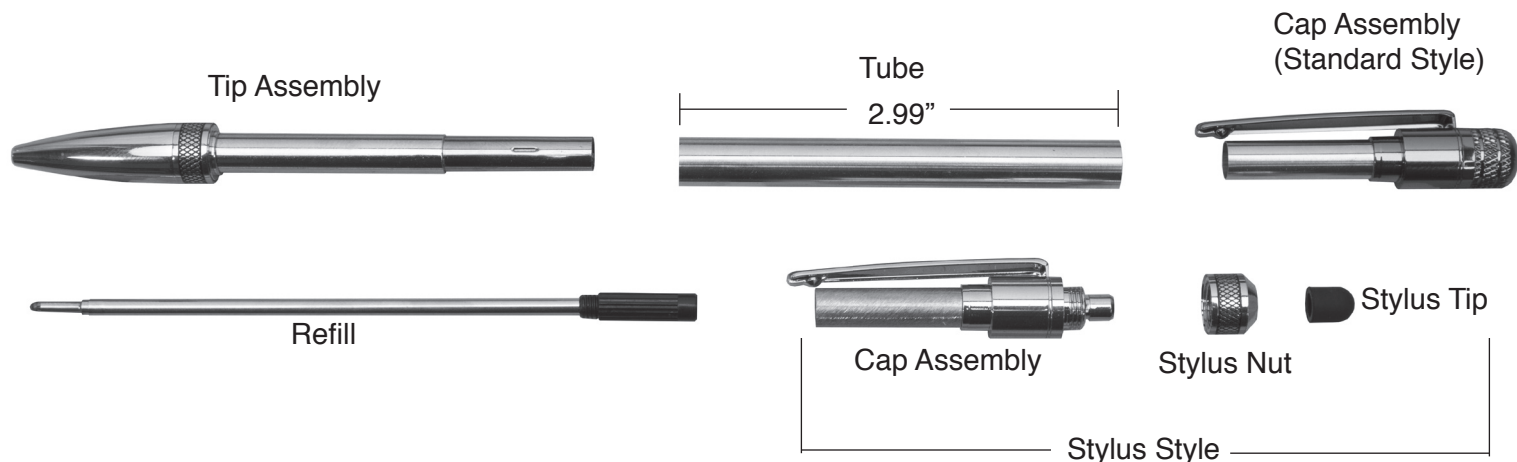

Preparing the Blank:

- Cut 1 blank to the length of the tube, adding 1/16" for squaring off.
- Drill 8mm hole lengthwise through the blank.
- Spread glue over the tube, insert the tube into the blank with a twisting motion to spread the glue evenly inside.
- Center the tube lengthwise inside the blank.
- When the glue is dry, square the ends of the blanks, making sure the trimmed ends are 90° to the tube. Use a 3/8" barrel trimmer, or a pen blank squaring jig with a 3/8" sleeve on a disc sander. Take the excess material down flush to the ends of the tubes. Do not trim past the end of the tube since this may interfere with the operation of the mechanism and assembly. Use a barrel trimmer to clean the inside of the tube.

DIAGRAM B / TURNING THE BLANKS

**Turning the Blank**

- Mount the bushings and blanks according to diagram B.
- Thread on the knurled nut and hand tighten to hold all components in place.
- Slide the Tailstock up snugly against the Mandrel shaft, inserting the live center point into the Mandrel dimple. Lock Tailstock.
- Hand tighten the quill adjustment on the tailstock to steady the mandrel. Do not overtighten, it could damage the mandrel shaft.
- When using Mandrel Saver, there is no need for extra spacer bushings or the knurled nut. Slide tailstock directly against bushings and tighten until blank and bushings are secure.
- Using sharp tools, turn the blank down close to the bushing diameter. Turn the barrel straight or to a profile of your choice.
- Sand the blank down to be flush with the bushings, gradually increasing sandpaper grits.
- Finish the barrel using your choice of polish. Allow Sufficient time for the polish to cure—refer to polish instructions.

Assembly

- Line parts up according to Diagram A. Leave Stylus Tip and Nut off of Stylus Assembly.
- To prevent damage from pressing, place bushing over the tip of the Stylus Cap and press into either side of the turned barrel. The Non-Stylus Cap Assembly can be pressed without using bushing.
- Thread Refill into back of Front Assembly. Front assembly can now be pushed (NOT PRESSED) into other end of Barrel. Insert until Front assembly is fully inserted into barrel. Fit should be firm but the tip should still be able to twist freely. Twist tip to extend and retract refill.
- To change refill, pull front assembly out of barrel and unthread refill. Replacement is done by reversing above steps.

Diagram C / Bushings #PKCORBU