

The Concava Twist Pen Kit

PKCON24 • PKCONGM • PKCONCH

Kit Features:

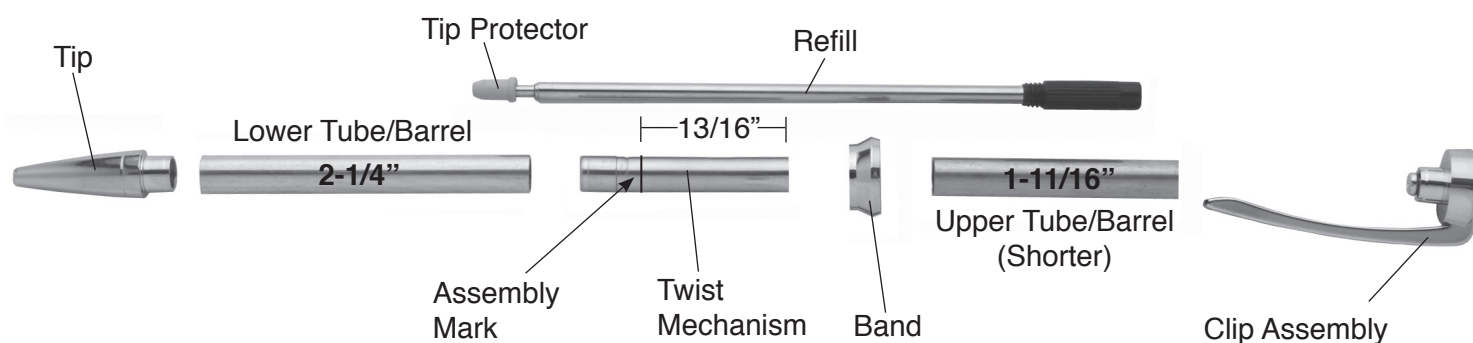
- Easy to turn 7mm pen with attractive concave profile
- Minimum parts - easy to assemble
- Available in multiple finishes
- Uses Cross® Style Refill
- Adjustable clip pressure
- Overall Length: 5-3/8"

Required Accessories:

- 7mm Pen Mandrel
- Drill Bit: 7mm #PK-7MM
- Bushing set(3 pc): #PKCONBU
- Barrel Trimming set: #PKTRIM7
- Live Tailstock Center
- 2 Part Epoxy Glue or Insta Cure (Cyanoacrylate) Glue
- Pen Blank: Minimum Size - 5/8" x 5"

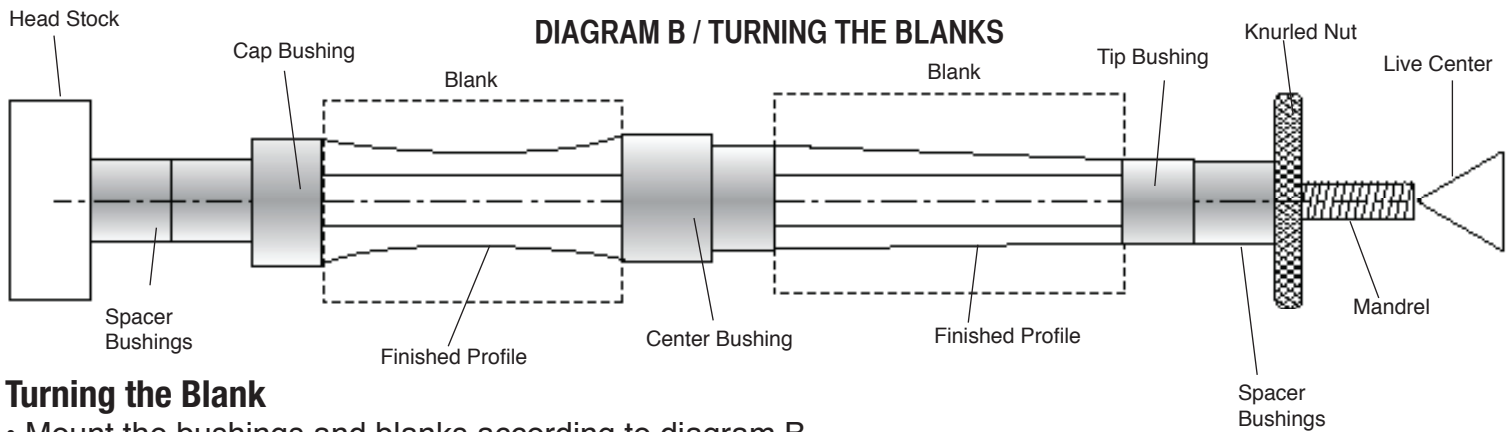


DIAGRAM A / PARTS LAYOUT



Preparing the Blank:

- Cut 2 blanks to the length of the tube(s) and add 1/16" for squaring off.
- Drill 7mm holes lengthwise through the blanks.
- Spread glue over the tube(s), insert the blank with a twisting motion to spread the glue evenly inside. Center the tubes lengthwise inside the blanks.
- When the glue is dry, square the ends of the blanks. You can use a 7mm barrel trimmer. Take the excess material down flush with the ends of the brass tube. (do not trim beyond the length of the tube since this may interfere with operation of the mechanism and assembly).



Turning the Blank

- Mount the bushings and blanks according to diagram B.
- Thread on the knurled nut and hand tighten to hold all components in place.
- Slide the tailstock up snugly against the mandrel shaft inserting the live center point into the mandrel dimple, lock in place.
- Hand tighten the quill adjustment to firm up the mandrel. (DO NOT overtighten, it could damage the mandrel.)
- Using sharp tools, turn the blank down close to the bushing diameter. Turn the barrel, follow Dia. B for profiles on upper and lower barrels.
- Sand the blank down to be flush with the bushings gradually increasing the sandpaper grits.
- Finish the barrel with your choice of polish. Allow sufficient time for the polish to cure. Refer to polish instructions.

Assembly

- Layout parts according to diagram A.
- Insert and press clip into either end of the upper barrel.
- Press the tip into the narrow end of the lower barrel.
- Mark 13/16" on the chrome end of the twist mechanism.
- Press the twist mechanism brass end in first into the opposite end of the lower barrel. Stop at the mark. Test for refill extension.
- Affix the center band over the extended chrome of the twist mechanism, slide on narrow end first.
- Remove the protector from the refill tip, insert the refill into the lower barrel, screw in.
- Engage the 2 ends of the pen.
- The pen operates by twisting the ends to extend or retract the refill.

Diagram C / Bushings #PKCONBU

