

ITEM #PKCLPEN Clip-On Pen Kit

KIT FEATURES

- Designed to carry on belt loop. Quick release spring clip. Compact Size.
- 24 Karat Gold plating with epoxy coating
- Twist mechanism to retract or extend the refill
- Uses mini refill (#PKMINI-R5)
- Overall size: 4-5/16"

REQUIRED ACCESSORIES

- 7mm, long mandrel
- 7mm Drill bit, (#PK-7mm)
- 3 piece bushing set (#PKCLBU)
- 7mm Barrel Trimmer, (#PKTRIM)
- 2 part Epoxy Glue, or Insta-cure (cyanoacrylate) glue

Diagram A - Parts List

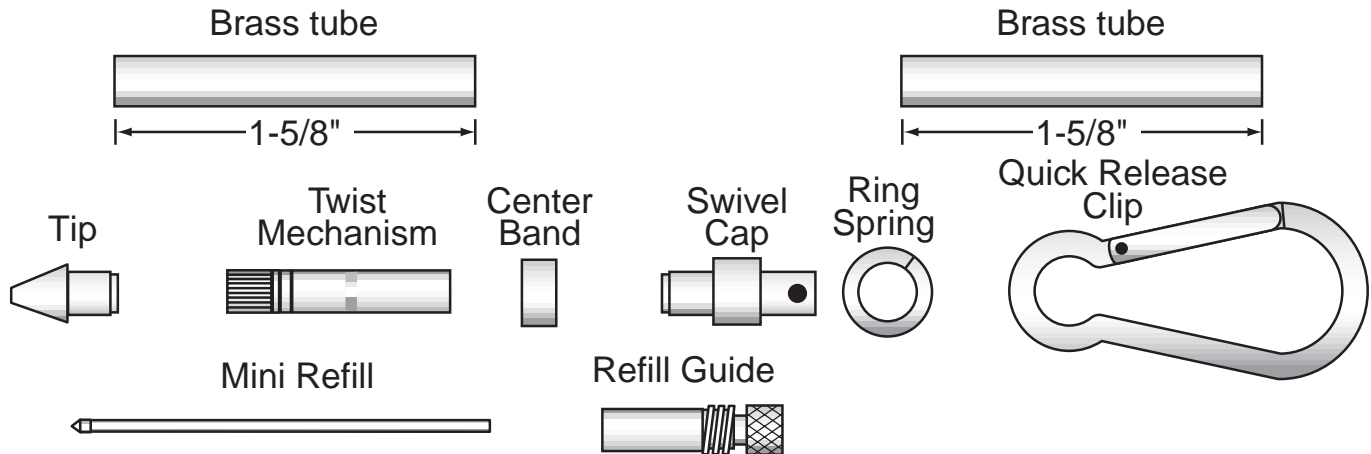

PREPARING THE BLANKS

- Cut 5/8" square blanks to the length of the brass tubes (add 1/16" for squaring off)
- Drill a 7mm-center hole lengthwise through each blank.
- Spread glue over the brass tube. Insert into the blank with a twisting motion to spread the glue evenly inside.
- When the glue dries, square the ends of each blank using a barrel trimmer.

Diagram B - Turning the Blanks

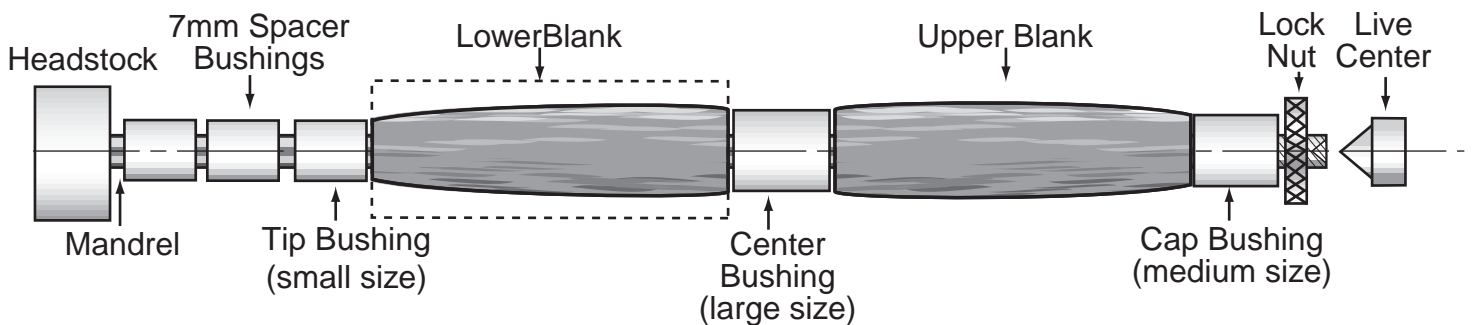

TURNING THE BLANKS

- Place three or four standard 7mm bushings onto the mandrel, followed by the lower blank, the large size center bushing, the upper cap blank and lastly the medium size cap bushing. Use additional bushings to fill the space on the shaft up to the threads.
- Hand tighten the lock nut to hold all items in place.
- Slide the tail stock snug to the mandrel shaft, (do not over tighten, it could damage the mandrel). Lock in place.
- Turn the wood down, flush with the bushings using lathe tools and gradual higher grits of sandpaper.
- Sand the wood and finish with friction polish or use PSI clear hi-gloss project finish #HGPF off the lathe for a brilliant finish.

Diagram C - Pen Assembly

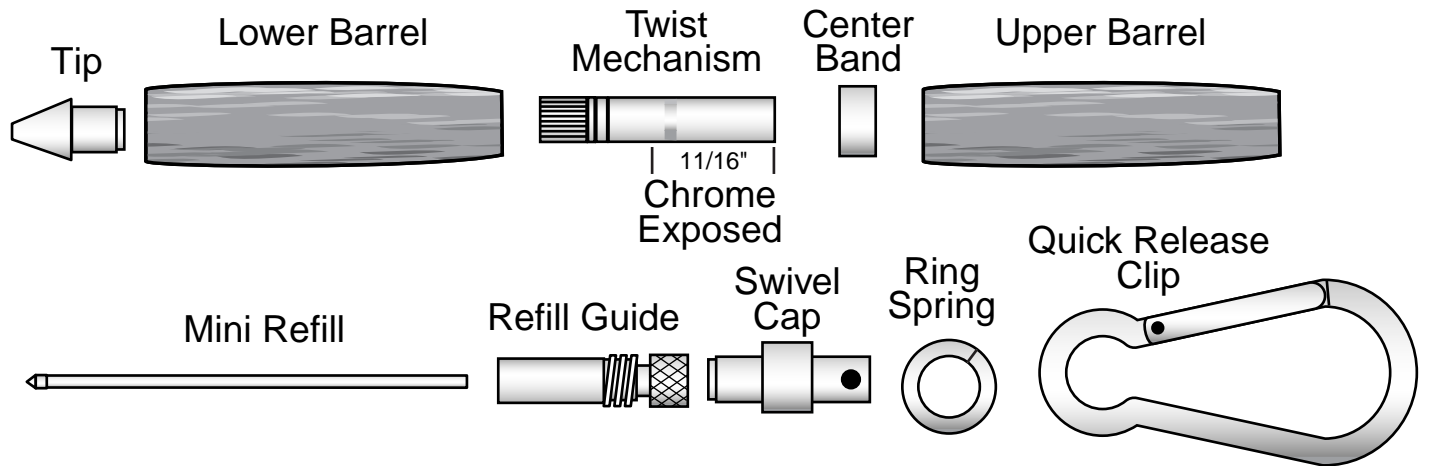

ASSEMBLY

- Line up finished parts according to Diagram C
- Press the tip into the narrow end of the lower barrel,
- Press the twist mechanism, brass end first, into the opposite end of the lower barrel until 11/16" of the chrome end is exposed outside (*refer to Diagram C*)
- Push the refill all the way into the bottom of the refill guide.
- Thread refill guide into the twist mechanism to the end. Test for full extension.
- Slip the center band over the exposed mechanism
- Press the swivel cap onto the narrow end of the upper barrel.
- Insert the ring spring into the hole and attach the clip.
- Engage upper and lower barrels
- Pen operates by twisting motion to retract or extend the refill.

Diagram D - Bushing Set #PKCLBU

