

Eye Brush Set Kit



Kit Features:

- Easy to turn
- Minimum parts - easy to assemble
- 4 Styles per set
- May use long peices of scrap wood
- Available in multiple brush and ferrule styles

Required Accessories:

- 2 Part Epoxy Glue or Insta Cure (Cyanoacrylate) Glue
- Blank: Minimum Size - approx. 1/2" sq x 5" to 8" Long (pen blank OK)
- Live Tailstock Center
- Drive Center

Preparing the Blank:

- Mark the center on each end of the blank, drill small pilot holes.

DIAGRAM A / PARTS LAYOUT



DIAGRAM B / TURNING THE BLANKS

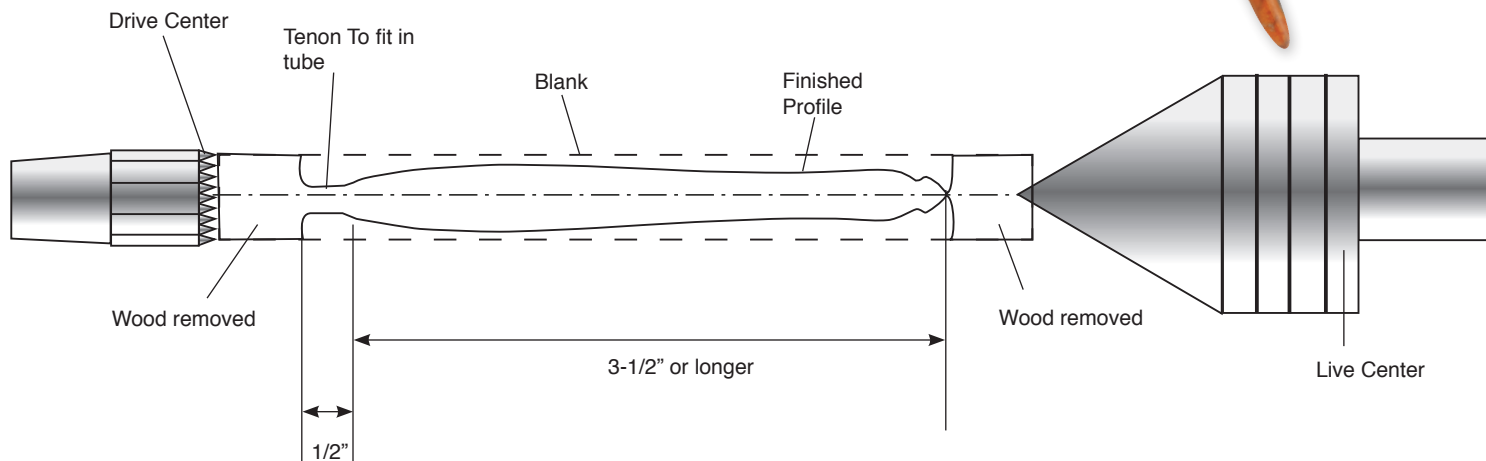

Turning the Blank

- Mount the handle blank between centers (see diagram B).
- Remove material to create a profile of your choice.
- Turn to the large dia to start while gradually moving to the smaller dia so the material will not weaken and break before it is complete.
- Turn the tenon to fit inside the tube of the brush. Use either a caliper or make a gauge to determine the diameter of the tenon.
- Sand and finish the handle.
- Use a skew or parting tool to separate the handle from the remaining blank.
- Place drops of glue inside the tube. insert the tenon.
- The brush is now ready to use.

