

# Cameo Twist Pen Kit

## Kit Features:

- Easy to turn with straight tubes
- Minimum parts - easy to assemble
- Available in multiple finishes
- Use Parker® Style Refills
- Overall length: 5-1/2"

## Required Accessories:

- 7mm Pen Mandrel
- Drill Bit: 8mm #PKPARK-8MM
- Drill Bit: 3/8" #PKEXEC-38
- Bushing set (3 pc) #PKCAMBU
- Barrel Trimming set #PKTRIMKIT 8MM & 3/8"
- Live Tailstock Center
- 2 Part Epoxy Glue or Insta Cure (Cyanoacrylate) Glue
- Pen Blank: Minimum Size - 3/4" X 4" Long



## DIAGRAM A / PARTS LAYOUT

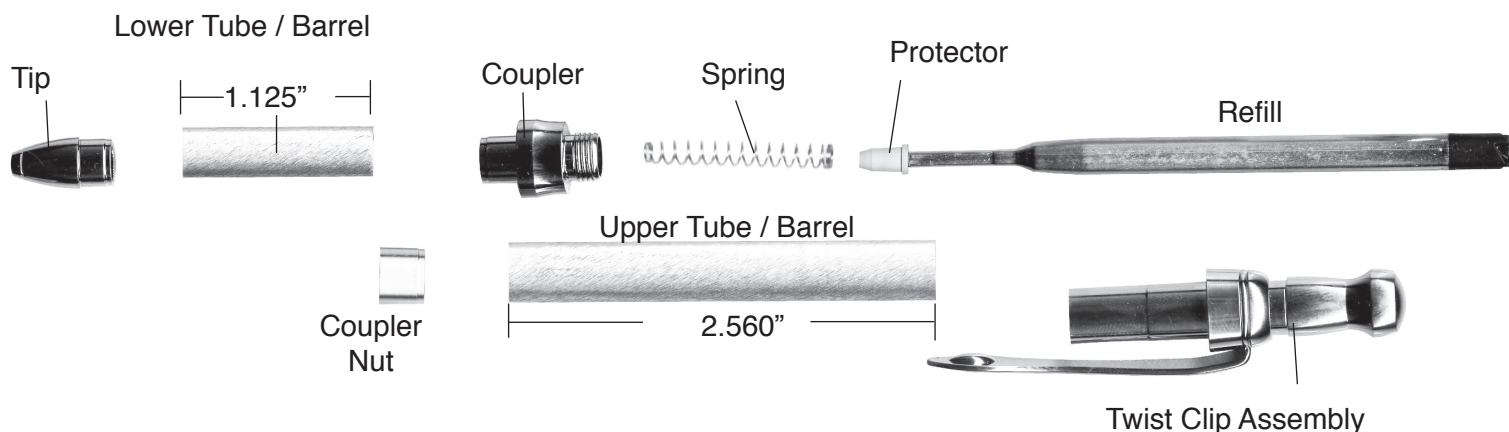

## Preparing the Blank:

- Cut 2 blanks to the length of the tubes and add 1/16" for squaring off.
- Drill 3/8" lengthwise through the upper (longer) blank. Drill an 8mm hole in the bottom blank (shorter).
- Spread glue over the tube(s), insert into the blanks with a twisting motion to spread the glue evenly inside.
- Center the tubes lengthwise inside the blanks.
- When the glue is dry, square the ends of the blanks. Use a 8mm & 3/8" barrel trimmer, or a universal pen blank squaring jig with a power disc sander. Take the excess material down flush with the ends of the brass tube. (do not trim beyond the length of the tube since this may interfere with operation of the mechanism and assembly).

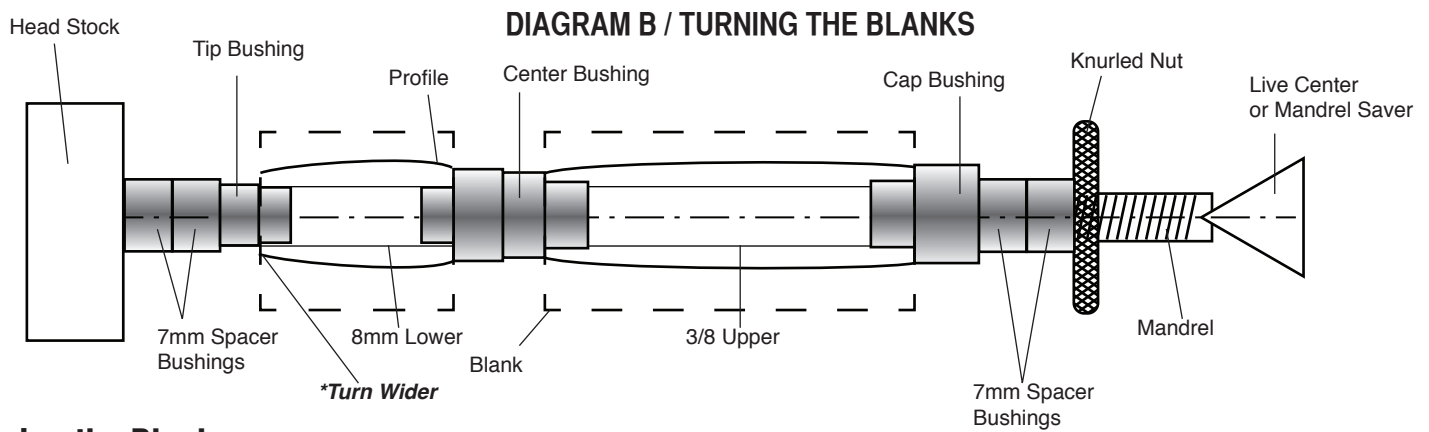

### Turning the Blank

- Mount the bushings and blanks according to diagram B.
- Thread on the knurled nut and hand tighten to hold all components in place.
- Slide the tailstock up snugly against the mandrel shaft inserting the live center point into the mandrel dimple, lock in place.
- Hand tighten the quill adjustment to firm up the mandrel. (DO NOT overtighten, it could damage the mandrel.
- Using sharp tools, turn the blank down close to the bushing diameter. Turn the barrel (straight or to a profile of your choice) **\*Turn the barrel at the tip end wider. (See diagram B)**
- Sand the blank down to be flush with the bushings gradually increasing the sandpaper grits.
- Finish the barrel with your choice of wood or acrylic polish. Refer to polish instructions.

### Assembly

- Layout parts according to diagram A
- Press the tip into the smaller dia. of the lower barrel.
- Press the coupler, extension end in first into the smaller diameter end of the lower barrel.
- Press the coupler nut, recessed end in first into the smaller diameter end of the upper barrel.
- Press the twist/clip assembly, recessed end in first into the opposite end of the upper barrel.
- Remove the tip protector, affix the spring over and insert into the opening at the coupler.
- Place the upper end of the pen over the refill. Screw to bottom.
- The pen operates by twisting the cap to extend or retract the refill tip.

### Diagram C / Bushings #PKCAMBU

