

Bandsaw Sled for Sizing & Squaring Pen Blanks

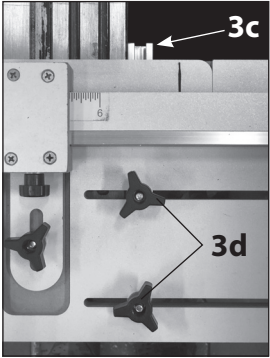

Make sure you attach and square your sled to the bandsaw table using the Adjustment Knobs (3d) and Adjustable T-Track (3a) Keep sled tight against the sides of the table.

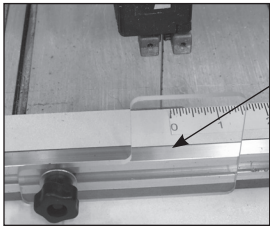

Position the safety guard in front of the blade

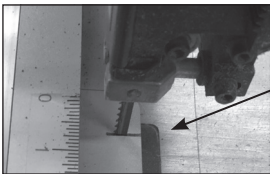

Make cut in waste piece to see cut line

NOTE: waste piece can be replaced with masonite or plywood

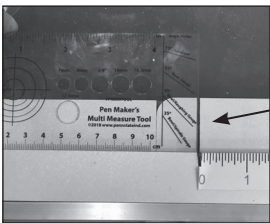

Use PSI Multi Tool or a Credit Card to square the fence (2) with to the waste cut. Secure with Fence Lock Knob (2d)

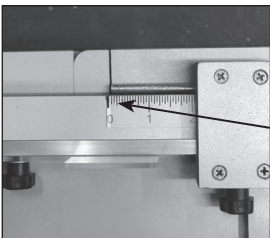

Set your cut length with your tube. Leave extra length for squaring

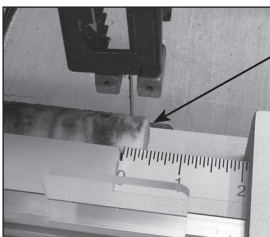

Get a square initial cut on the blank.

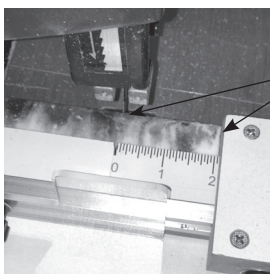

Slide the squared end up to block and cut. Finished with a perfect squared cut every time!

See website for Video

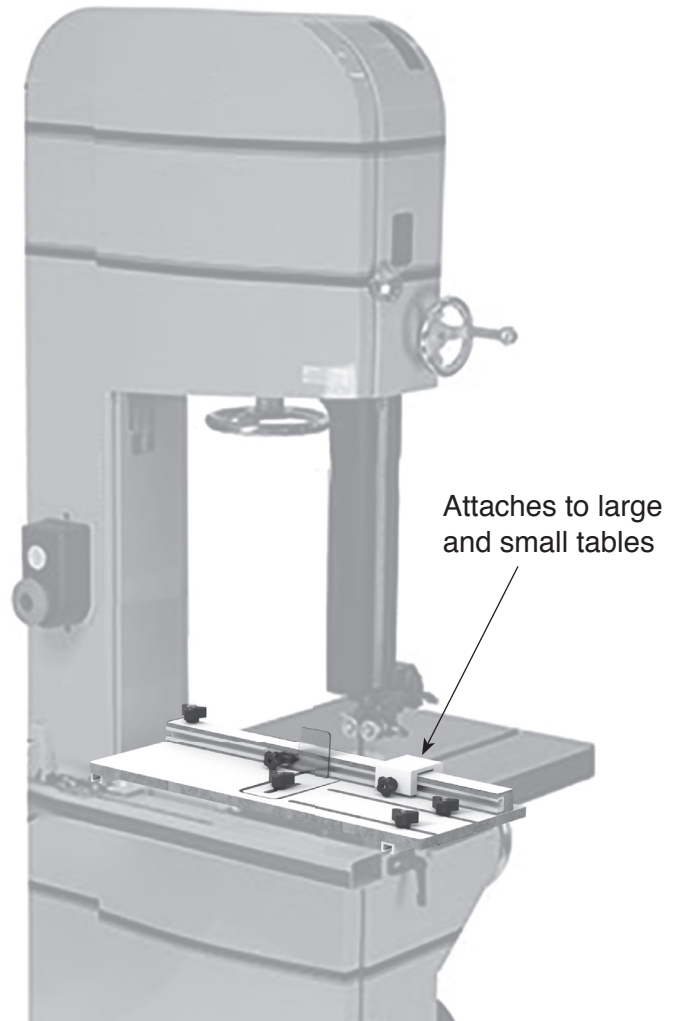

Attaches to large and small tables

