

Big Ben Click Pencil

PKBIGCLI • PKBIGCL2 • PKBIGCL3

REQUIRED ACCESSORIES

- 7mm Pen Mandrel
- 3 pcs. Bushing Set #PKBIG-BU
- 10mm Drill Bit #PK10-10
- Universal Barrel Trimming #PKTRIMKIT (Use 10mm)
- 2 Part EpoxyGlue or Insta Cure (cyanoacrylate) glue
- Pencil uses 2mm lead #PKPOWLEAD 20/PK
- Pencil erasers replacement #PK-PCLE10 10/PK
- Overall length: 5-1/2"

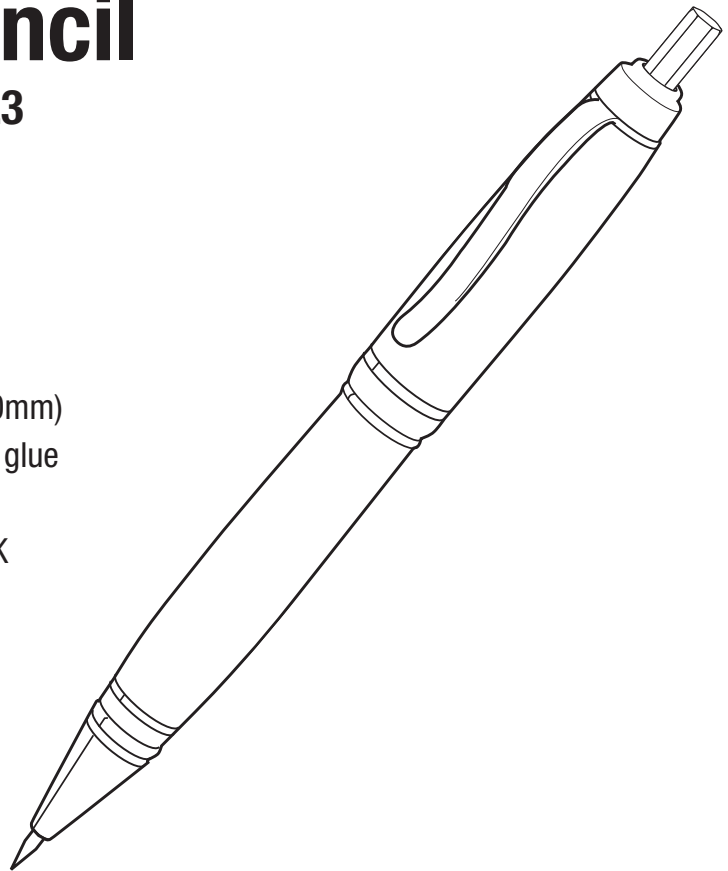
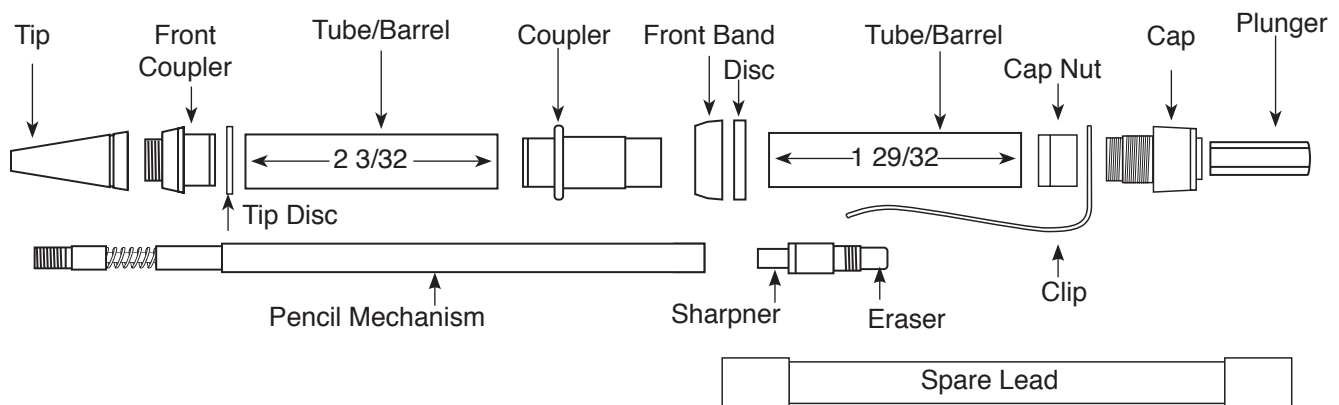

DIAGRAM A / PART LIST.



PREPARING THE BLANKS

- Cut the blanks to the size of the brass tube (add $\frac{1}{16}$ " for trimming)
- Drill 10mm hole, through each blank.
- Glue each tube in the blank. Insert with a twisting motion to spread the glue evenly inside the blank.
- When the glue dries, use a universal 10mm barrel trimmer.
Trim the wood down, flush to the brass tube.

DIAGRAM B / Turning the Blanks

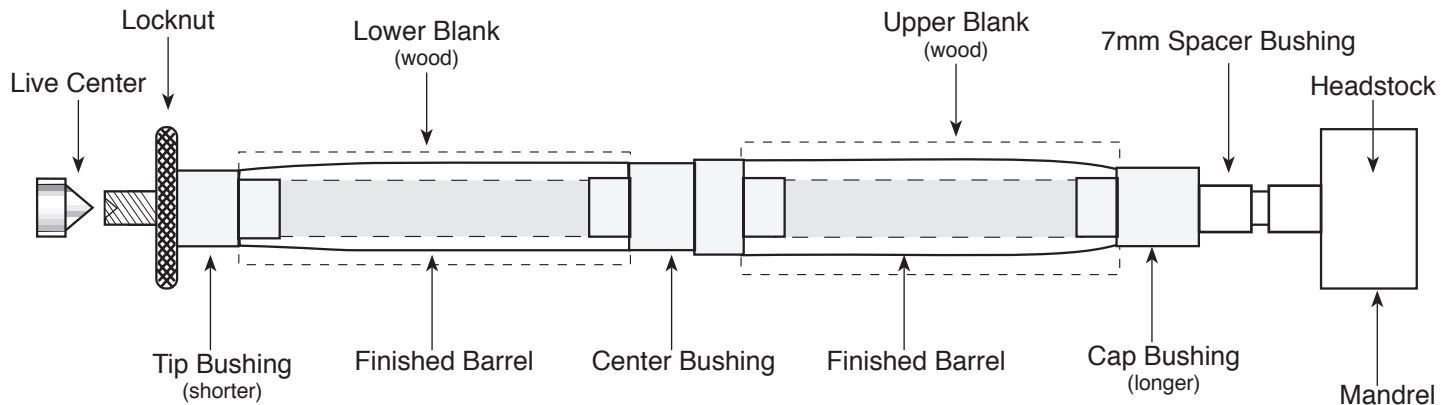

TURNING THE BLANKS

- Mount the bushings and blanks on the mandrel according to Diagram "B"
- Turn the wood down, close to size of the bushings. Sand the wood down to the bushing diameter.
- Finish the wood with your choice of polish.

ASSEMBLY *Note: Layout finished parts according to Diagram A*

- Mount the tip disc over the extension of the front coupler press this assembly into the narrow end of the lower barrel.
- Press the coupler, short extension in first into the opposite end of the lower barrel.
- Mount the front band and disc over the exposed coupler. Press into the wide end of the upper barrel.
- Press the Cap Nut, recessed end in first into the opposite end of the upper barrel.
- Mount the clip over the cap, screw into the Cap Nut.
- Drop the Pencil Mechanism into the opening at the Cap until the thread is exposed.
- Insert and screw the tip over the mechanism thread-tight.
- Screw the plunger over the eraser-tight.
- The pencil is ready to operate by clicking on the plunger to advance the lead.
- To sharpen the lead, just pull out the plunger, the sharpener will be exposed on the opposite side. Insert the lead tip into the designated hole and spin. Be sure to dispose of the lead dust after use.
- To use the eraser, unscrew the plunger.
- To refill with new lead, remove the plunger/sharpener and drop new lead inside.

DIAGRAM C / PKBIG-BU

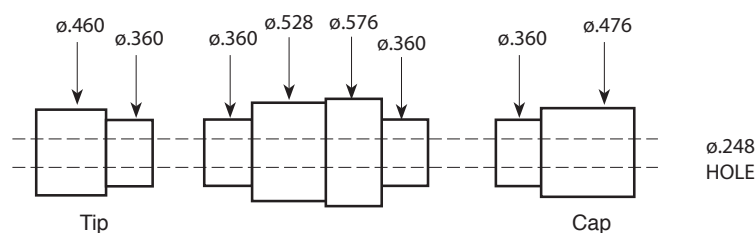

Philadelphia, PA 19115