

David Broadwell's Art Deco Rollerball & Fountain Pen Kit Instructions

KIT FEATURES

- A modern Art Deco look
- Pen components carefully crafted under high quality inspection
- Heavy, 2-micron plating. Attention to details on the components.
- Uses high quality Geiman made Schmidt® Ceramic Roller refill or high quality German made Iridium Tip fountain pen nib
- Overall length: 6-1/2" open

REQUIRED ACCESSORIES

- 7mm Mandrel
- Drill Bits: 10.5mm #PK105MM (for lower tube)
12.5mm #PKPLI-DB (for upper tube)
- 3-pc bushing set #PKARTBU
- Barrel Trimmer #PKTRIM7 (use with sleeves below)
- Barrel Trimmer Sleeve Set #PKMAJJRBTs
- 2-part epoxy glue or insta-cure (cyanoacrylate) glue.



DIAGRAM A – PARTS LIST

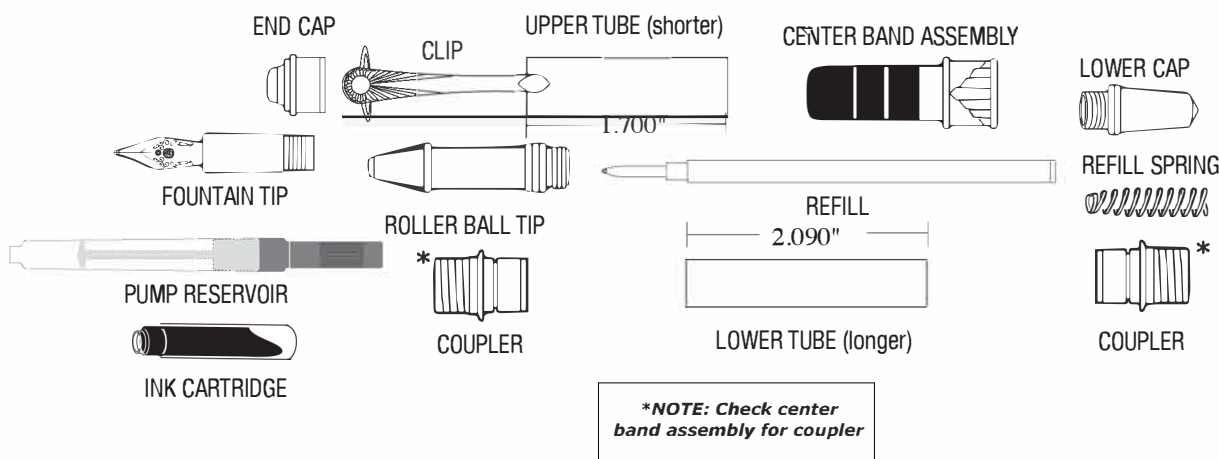

PREPARING THE BLANK

- Prepare a master blank of at least 3/4" square. Cut two sections to the length of each tube (add a 1/16" for trimming). Mark the center of each blank
- Upper Blank (shorter tube) - drill a 12.5mm hole through upper blank
- Lower Blank (longer tube) - drill a 10.5mm hole through lower blank
- Glue each tube in the proper blank. Spread glue evenly over each tube. Insert the tube into the blank with a twisting motion to spread the glue evenly inside. NOTE: You may sand the tubes using 220-grit abrasive for better adhesion. Center each tube lengthwise inside the blank.
- When glue dries; square the ends of each blank. Use a 7mm barrel trimmer with adapter sleeves; mount the proper sleeve (large diameter for the shorter tube, smaller diameter for the longer tube) over the shank. Trim the blank down flush with the brass tube.

DIAGRAM B – TURNING THE BLANKS

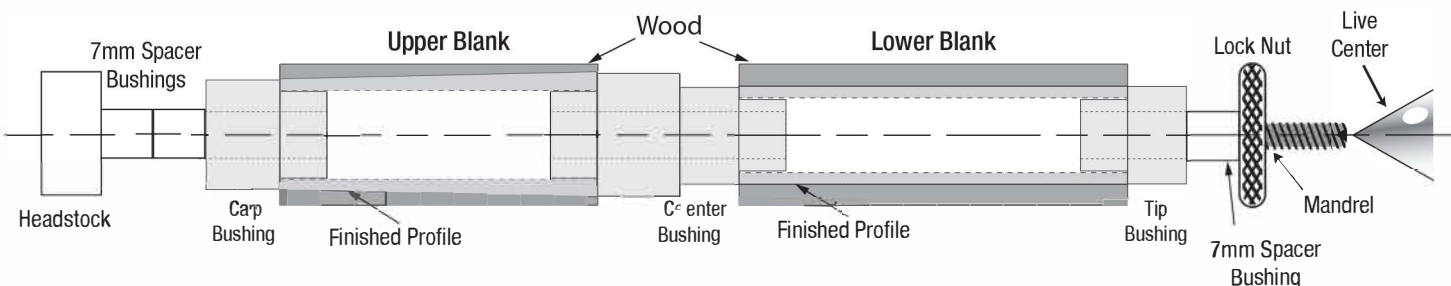

TURNING THE BLANKS

- Mount spacer bushings on the mandrel. Slide the cap bushing (wider diameter) wide end in first. Slide the upper blank (shorter) on next. Follow with the center bushing, wider diameter on first. Slide on the lower blank and follow with the tip bushing, narrow end in first. Mount spacer bushings to fill the space to the threads on the mandrel. Screw on the lock-nut hand tight. Bring the tailstock in snug to the mandrel. Lock in place. Do not over-tighten the lock nut; it may damage the mandrel.
- Turn the blanks down close to the bushings. Follow with abrasives until the tube diameters are flush with the bushings. Finish with your choice of polish.

DIAGRAM C – ASSEMBLY



***NOTE: Check center band assembly for coupler**

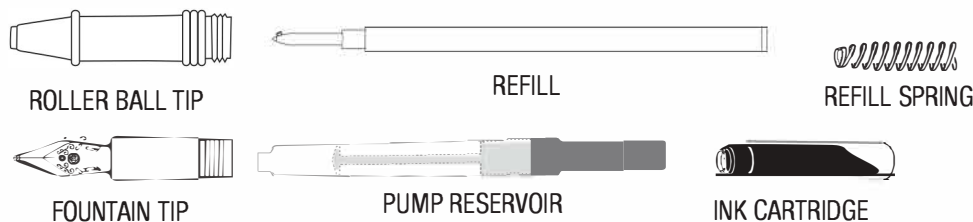

ASSEMBLY

- Line up components according to Diagram C. To avoid damage to components when assembling pen, use PSI# PENPRESS4.
- Press the center band assembly into the upper (shorter) barrel.
- Insert the clip over the cap; press this assembly into the opposite end of the barrel.
- IMPORTANT: the clip must align with the high point of the band design.
- Press one coupler assembly into the lower tube.
- Press the other assembly into the opposite side of the lower barrel.
- Screw the lower cap over the exposed threads.

ROLLER BALL

- Insert the refill spring, wide end in first into the opening at the lower end of the pen; follow with the pen refill, wide end in first.
- Thread on the roller tip over the threaded coupler.

FOUNTAIN PEN

- Affix the ink reservoir; narrow end in first into the back of the pen nib. Push in to break the seal (or use PSI refillable reservoirs#PKPUMP5), then press lightly to advance the ink forward.
- Thread the fountain nib assembly over the threaded coupler.

TIPS

- When engaging the ends to close the pen, notice the threads have three starting points, so you can quickly close the pen in any of the three positions.
- You may also want to consider matching the wood grain when assembling the pen.

DIAGRAM D – BUSHINGS

#PKARTBU

