

# Car Air Freshener Vent Clip Kit

## Kit Features:

- Stylish and Practical Accent for your Car
- Spinning Fan helps distribute scent
- Scent can be Refreshed with Aromatherapy Oils
- Minimal Parts--easy to assemble
- Overall Size: 1-5/8" deep, 1-1/2" round
- USES REFILL: Pre-scented Chips #PKAIRFN, #PKAIRFC, #PKAIRFL
- or Use your own Scents with #PKAIRFX
- Includes one chip w/aroma, one chip without

## Required Accessories:

- 1" Jam Chuck #CJAM1 with Headstock Mounted DrillChuck #TM42
- Drill Bit: 1-1/8" #PKSB118
- 2 part Epoxy.
- Blank Minimum Size: 1-1/2" x 1-1/2" x 3/4"L



Kit shown attached to car vent

## DIAGRAM A / PARTS LAYOUT

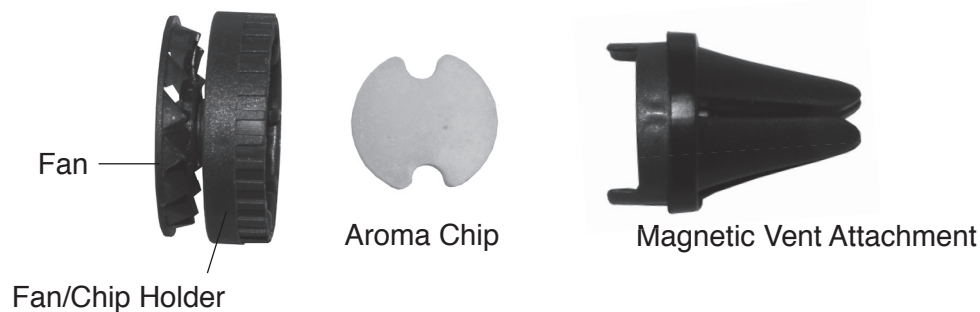

## Preparing the Blank:

- Cut 3/4" section of a 1-1/2" square blank. **Note: a wider blank will allow a more rounded profile.**
- Mark center of the wide face of the blank.
- Drill 1-1/8" hole lengthwise through the blank.

## DIAGRAM B / TURNING THE BLANKS

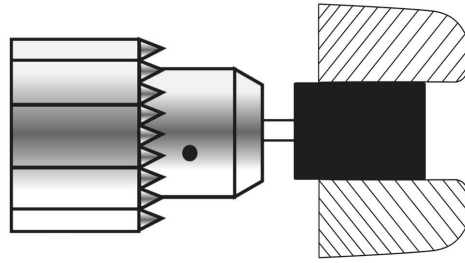

## Turning the Blank

- Mount the #TM42 Drill Chuck onto your lathe.
- Insert the Jam Chuck and tighten the jaws. Leave enough room on shaft to allow you to tighten the nut on the Jam Chuck.
- Use Pliers or a 7/16" wrench to turn the nut on the rear end of the 1" Jam Chuck until it is almost as wide as the drilled hole.
- Slip the Blank over the Jam Chuck and position it so the inside of the blank overhangs the Jam Chuck by about 1/4".
- Tighten the nut and make sure before final tightening that the ends of the blank are as straight as possible.
- Tighten Jam Chuck enough that the blank does not slip on the rubber. If you start turning and the Blank slips, or the ends seem to wobble too much, stop the lathe and adjust the Jam C and blank accordingly.
- Using sharp tools, turn the blank round. Turn the barrel straight or to a profile of your choice.
- Carefully turn the area at the opening of the hole. Try to make a slight funnel or a curved transition into the hole. Be careful not to hit jam chuck with your tools.
- Sand the blank down to a ring, gradually increasing sandpaper grits. Be sure to sand the exposed portions in the hole.
- Finish the sanded ring using your choice of polish. Allow Sufficient time for the polish to cure—refer to polish instructions.
- Loosen the jam chuck and remove finished piece. You may wish to lightly sand and hand polish the back and interior areas.

## Assembly

Make a parts holding jig

- You will need a scrap piece of wood that is wider than the opening in the blank. It should have a flat surface.
- Mark the center of the scrap piece and drill a 3/16" hole at least 1/8" deep. (See Diagram C)
- Place the Fan/Chip Holder with fan side down onto the jig. The hub should rest inside the hole, so the outer rim sits flat.
- Slide your Blank over the back of the Fan/Chip Holder and mark a line inside the hole where the back of the holder sits.
- Remove the Blank and mix 2-part epoxy and spread inside the hole below the marked line where the holder will be (See Diagram C). Epoxy can also be applied to the Holder for a stronger bond. If applying to the holder, be sure to wipe off excess so that the slots are filled and there is only a thin film on the surface to minimize glue scraping off when inserting into blank.
- Set holder on the jig as before. Carefully slide Blank over it until it both sit flat on the scrap piece and allow epoxy to cure.
- Place Scent Chip Diagram D into the space in the back of the Holder, followed by the Vent Attachment. The Freshener is now ready to attach to the car vent.
- To replace the chip, simply pull the Fan chip assembly from the vent attachment remove the old chip and put a new one in place. If using an unscented chip. A few drops of Aromatherapy oil onto the chip is all that is needed to load it with the chosen scent. The chip can be refreshed whenever necessary.

## Diagram C - Parts Holding Jig

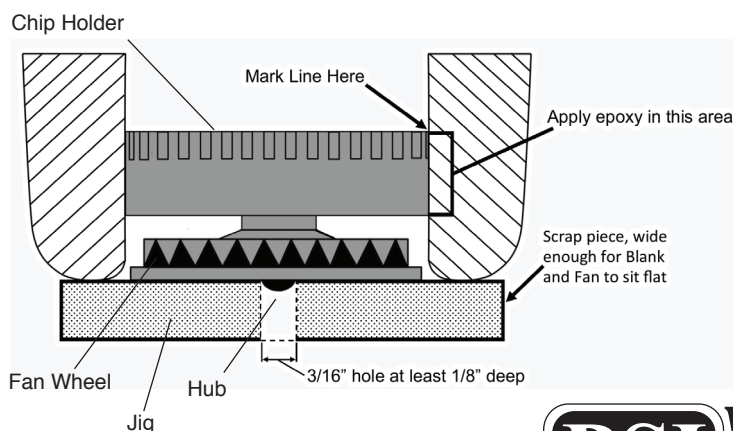

## Diagram D - Installing Chip

