

.50 Caliber Cartridge Twist Pen Kit



Kit Features:

- Uses genuine bullet cartridge
- Uses Cross™-style ball point refill
- 24kt gold-plated components
- Variable length
- Makes a freestanding desk accessory

Required Accessories:

- 7 mm, pen mandrel
- 7mm Barrel trimmer #PKTRIM7
- 2-pc bushing set #PK50CALBU
- Insta-cure (cyano acrylate) glue or 2-part epoxy glue
- #ONESTEP polish (to polish brass cartridge)

DIAGRAM A - Parts List

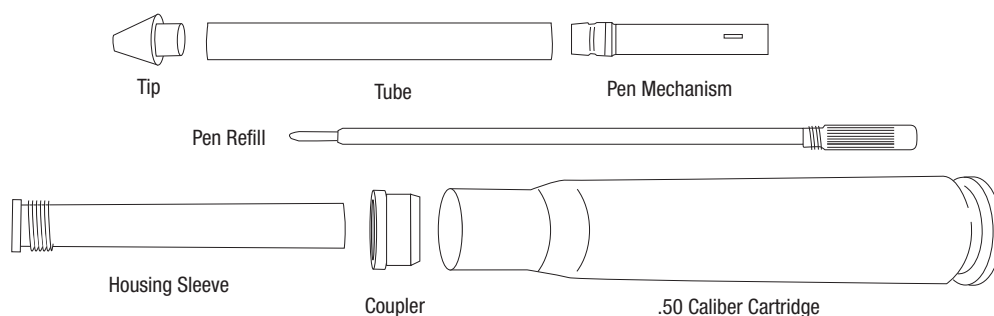

Preparing the Blank & Cartridge

- Cut 3/4" square blank to 1-3/16" (for 5-1/2" overall length pen) to 1-7/8" long (for a 6-3/16" overall length pen).
- Drill 7mm hole through the blank. Fired Cartridges require deburring and Rounding.
- Spread glue over an end of the tube to the size of the blank. Slide on the wood. Leave some wood over the edge of the brass tube for trimming. (Note: The wood only covers a section of the tube)
- When the glue dries, use a 7mm barrel trimmer to trim the wood flush to the end of the brass tube

DIAGRAM B - Squaring The Blank

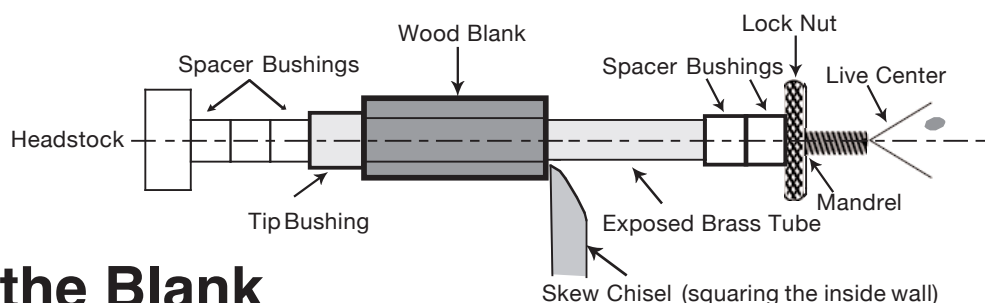

Turning the Blank

Note: Before turning the blank the inside wall of the blank needs to be trimmed square on the lathe.

- Mount spacer bushings on the mandrel shaft. Insert the tip bushing. Insert the front-end assembly, wood side in first. Follow with 7mm spacer bushings, fill to the mandrel threads. Use locknut to lock in the setup then position the tailstock for turning. Use a skew chisel or a parting tool to square the inside wall of the wood blank (see Dia. B). When squared, remove nut and spacer from the mandrel.
- Insert the center bushing over the brass tube, slide up tight to the wood. Add bushings as needed to close the space behind the outer bushing to the threads. See Diagram C. Lock in the set up then position the tailstock for turning. Turn the wood down close to the bushings. Follow the profile of an actual bullet on the wood barrel. Sand and polish the wood.

DIAGRAM C - Turning Profile To Bushings

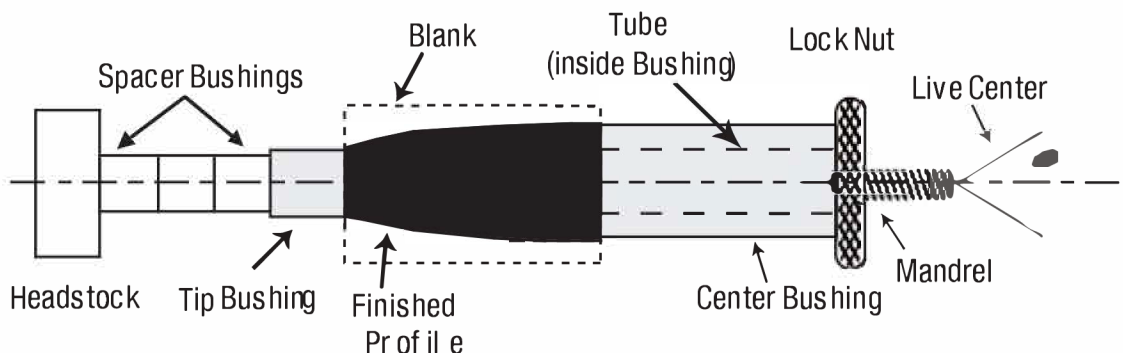
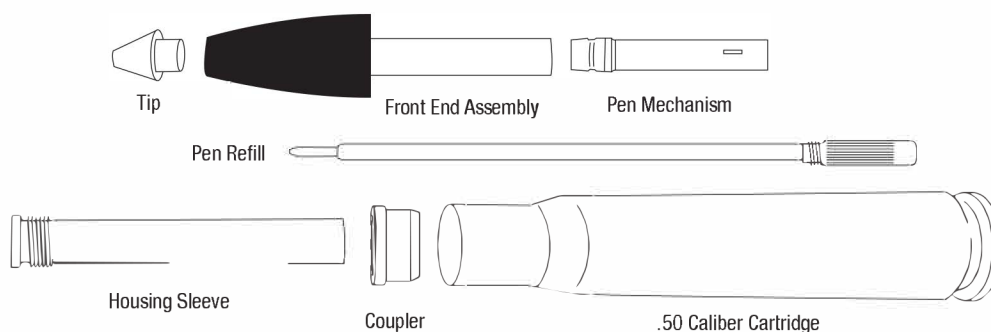

DIAGRAM D - Assembly



Assembly

Note: Before assembly of the pen parts; polish the brass cartridge to desired level of shine.

- Use a Jam chuck to hold the cartridge. Turn a wooden spindle about 4-5" long to fit snug in the opening of the cartridge. Mount the spindle into a drill chuck or a woodworking chuck, slide the cartridge onto the spindle; support outboard and turn on your lathe. Use a brass polish or #ONESTEP to polish the brass to a shine as it spins.
- Press the tip into the wooden end of the assembly.
- Press the pen mechanism, brass end in first into the opposite end to the indentation line. Insert the refill and test for refill tip extension.
- Press the coupler, narrow end in first into the opening of the cartridge until it seats.
- Thread the housing sleeve into the coupler.
- Slide the exposed brass tube into the housing sleeve, push in to bottom.
- The cartridge pen is ready to operate by twisting the ends.

BUSHINGS #PK50CALBU

