

The Mini 30 Caliber Bullet Cartridge Pen

#PK30M

Kit Features:

- Easy to turn with a straight tube
- Minimum parts - easy to assemble
- Provided with a once fired polished 30•06 shell casing
- Uses mini refill
- Overall length: 3-3/4"

Required Accessories:

- 7mm Pen Mandrel
- Drill Bit: 7MM, #PK-7MM
- #PKM-BUSH3, Bushing set(2 pc)
- #PKTRIM7, Barrel Trimming set
- Live Tailstock Center
- 2 Part Epoxy Glue or Insta Cure (Cyanoacrylate) Glue
- Pen Blank: Minimum Size- 1/2" x 1"

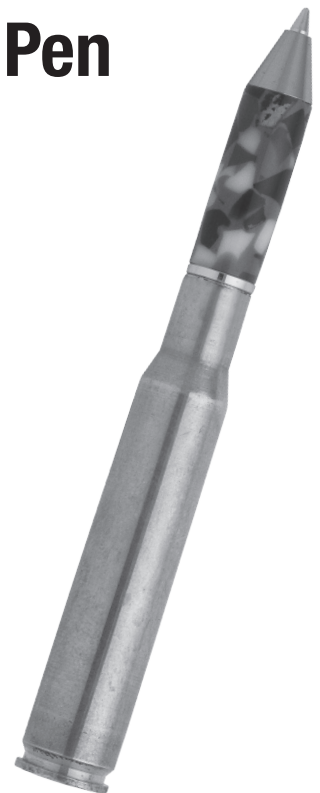
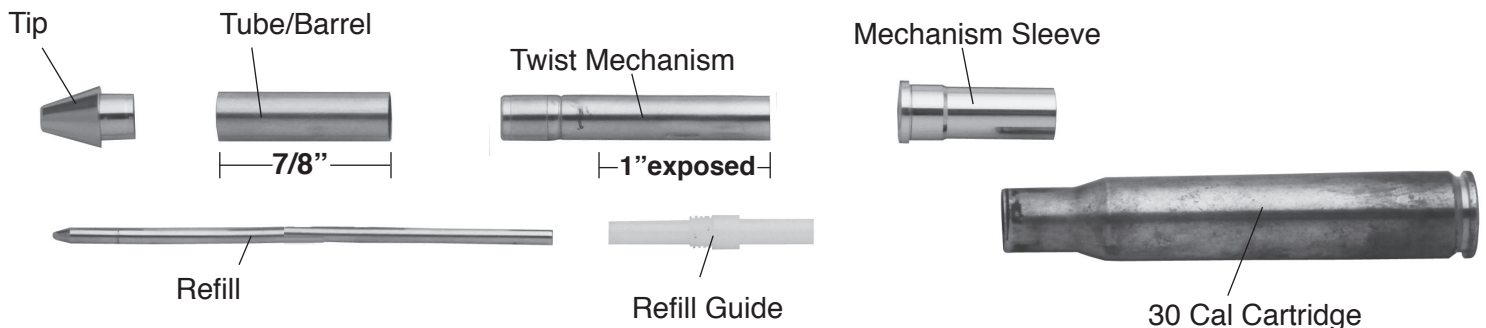

DIAGRAM A / PARTS LAYOUT



Preparing the Blank:

- Cut 1 blank to the length of the tube and add 1/16" for squaring off.
- Drill a 7 mm hole lengthwise through the blank.
- Spread glue over the tube, insert into the blank with a twisting motion to spread the glue evenly inside.
- Center the tubes lengthwise inside the blank.
- When the glue is dry, square the ends of the blank. Use a 7mm barrel trimmer, or a universal pen blank squaring jig with a power disc sander. Take the excess material down flush with the ends of the brass tube. (do not trim beyond the length of the tube since this may interfere with operation of the mechanism and assembly).

DIAGRAM B / TURNING THE BLANKS

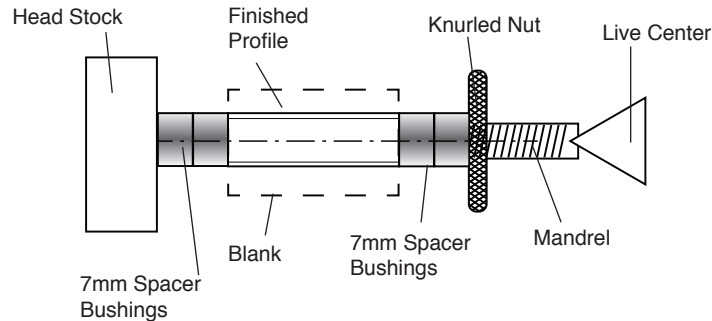

Turning the Blank

- Mount the bushings and blank according to diagram B.
- Thread on the knurled nut and hand tighten to hold all components in place.
- Slide the tailstock up snugly against the mandrel shaft inserting the live center point into the mandrel dimple, lock in place.
- Hand tighten the quill adjustment to firm up the mandrel. (DO NOT overtighten, it could damage the mandrel.)
- Using sharp tools, turn the blank down close to the bushing diameter. Turn the barrel (straight or to a profile of your choice)
- Sand the blank down to be flush with the bushings gradually increasing the sandpaper grits.
- Finish the barrel with your choice of polish. Allow sufficient time for the polish to cure. Refer to polish instructions.

Assembly

- Layout parts according to diagram A.
- Press the tip into either end of the barrel.
- Press the twist mechanism, brass end in first into the opposite end of the barrel. Stop when 1" of chrome is exposed.
- Insert the mini refill into the refill guide into the bottom. Insert this assembly into the back of the mechanism and screw in to the bottom. Check the extension of the refill.
- Insert the mechanism sleeve, narrow diameter in first into the opening of the cartridge, press to the shoulder.

NOTE: Since the cartridge is authentic & once fired- there may be variations in opening size from cartridge to cartridge. Use glue if the sleeve is too loose of a fit.

- Insert the exposed mechanism into the sleeve bottom.
- The pen operates by twisting the ends to advance or retract the refill.

Diagram C / Bushings #PKM-BUSH3

