

Multi Bit Lathe Chisel Set

Package Contents:

- A) Chisel handle & rod
- B) Set Screw
- C) 3mm Allen Wrench
- D) 2" Radius Carbide Bit
- E) Square Carbide Bit
- F) Round Carbide Bit
- G) Detail Carbide Bit
- H) Magnetic Chip Deflector

Safety:

- Use the right bit for the right job.
- Do not force the tool, proceed at a cutting speed that allows a smooth cut.
- Wear appropriate clothing when turning. Avoid loose clothes and long hair.
- Keep tool and work area clean.
- Always cut with a sharp bit. Replace a dull bit immediately.
- Use chip deflector with a dust collection hood for a clean work place.

General cutting tips:

To cut with flat bar along toolrest: (Diagram B)

Position the tool rest up or down so the cutting edge of the blade is in line with the center of the work piece. Position the blade so the flat side is in contact with the toolrest and the tool glides freely. When beginning the turning, slightly raise the handle until you reach the sweet spot when actual cutting occurs, slide the tool along the rest. Apply even pressure.

To cut with the round part of rod along toolrest: (Diagram C) (NOTE: Chip deflector can not be used in this position)

If you do not want the restriction associated with using the flat side of the rod and prefer free movement of the tool sideways, up or down, use the rounded side of the chisel rod. Loosen the set screw and rotate the bit 90°. Position the sharp end of the bit and the set screw upward. Glide the handle from side to side with a steady grip. Avoid rotating the handle.

Cutter Applications:

2" Radius Carbide Bit (D): Use this bit for roughing and removing wood and rounding a spindle. Bit is capable of forming large curves on handles. Move the bit sideways to achieve cutting on all 3 sides of the bit.

Square Carbide Bit (E): Use this bit for roughing a straight work piece to round. Glide the tool parallel to the work piece. Use all 3 sides of the bit for quick removing of wood. Bit can be used for parting, squaring ends and cutting a tenon with square corners.

Round Carbide Bit (F): Use this bit for turning a profile on a work piece. Works nicely to shape handles with curves and works well for hollowing bowls or cutting coves, 'U' shapes, and other rounded shapes. Leaves a smooth, handsome fine surface. Requires little sanding.

Detail Carbide Bit (G): Use this highly versatile cutter tip to carve coves and beads and for decorating intricate spindle work and final details on pens and other kit products. Cutter can be used for cutting tenon and as a parting tool. Using the tool with a light touch will leave a very smooth finished surface.

Replacement and extra parts:

You may find it convenient to have extra of your preferred cutters on hand and/or keep extra handles already set-up with a dedicated cutter. Use the parts list below for ordering extra system components:

Chisel Handle & Rod	LXMSETX
3 pack 2" Radius Carbide Bit.....	LXMSETA
3 pack Square Carbide Bit.....	LXMSETB
3 pack Round Carbide Bit.....	LXMSETC
3 pack Detail Carbide Bit.....	LXMSETD
Magnetic Chip Deflector	LXMSETM

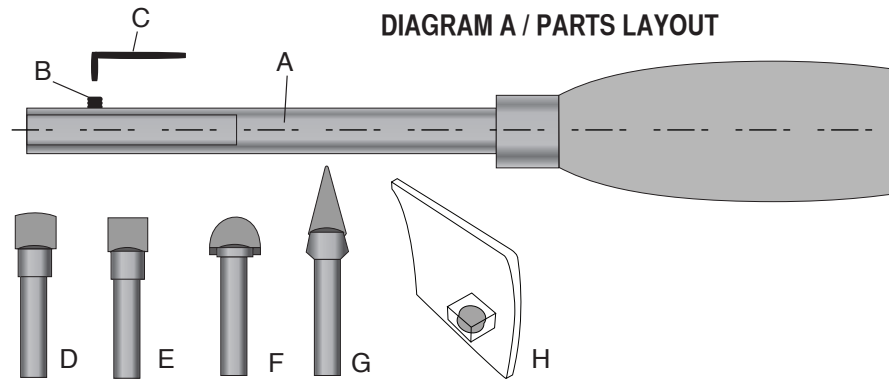

Assembly:

Slide Bit of choice into Hole at end of the chisel as far as possible. Lock in place with Alan Wrench. Position Magnetic Chip deflector on flat top of chisel as close as possible to end of Chisel. To replace bits, remove current bit and replace with any of the 3 other bits.

