

#KSWANDG (Green), #KSWANDR (Red) and #KSWANDB (Blue) Wand Kaleidoscope Kit

This PSI Kaleidoscope Wand Kit is easy to make, unusual and has a unique kaleidoscope design. The kit consists of a complete kaleidoscope mechanism that fits into a $2\frac{3}{16}$ " deep hole, drilled to a $\frac{13}{16}$ " diameter in a wooden blank. The eye piece and the end piece (wand holder) are designed to easily screw together for quick and secure assembly. A lens is included to allow for focusing on the viewing wand reflections.



TURNING THE WOOD BLANK

A proven procedure for turning a Wand Kaleidoscope blank is detailed below.

Diagram A

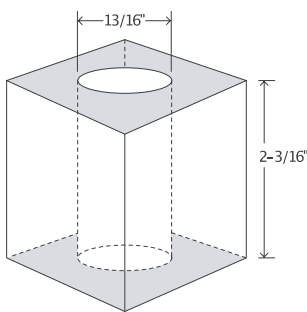

1. Use a block of wood $1\frac{1}{2}$ " to 2" square (depending on your design) cut to a length of $2\frac{3}{16}$ ". It is important that the length of the blank be $2\frac{3}{16}$ " in order for the mechanism to fit properly.
2. Determine the center of the square and drill a $\frac{13}{16}$ " hole completely through (use a PSI $\frac{13}{16}$ " forstner bit #KSEG-DB). If the wood is to be left natural you should drill through the end again.
3. Use PSI bushing set (item # KSEG-M) to mount and turn the blank on your lathe. These kaleidoscope bushings are "step bushing" that slide onto PSI 7mm pen making mandrel.

Diagram B: TURNING THE BLANK

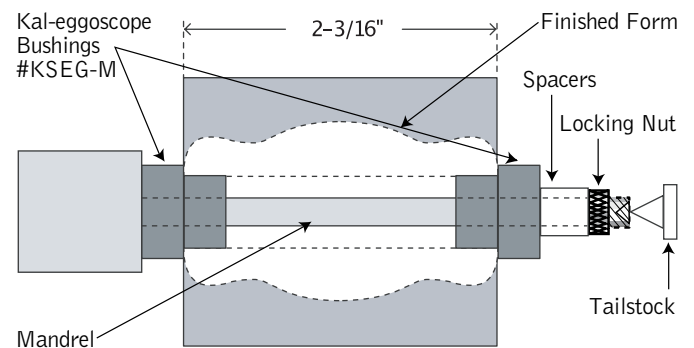

ASSEMBLY OF WAND KALEIDOSCOPE KIT

Account for all parts shown in the figure above. Refer to this figure for positioning and assembly of all components.

Diagram C

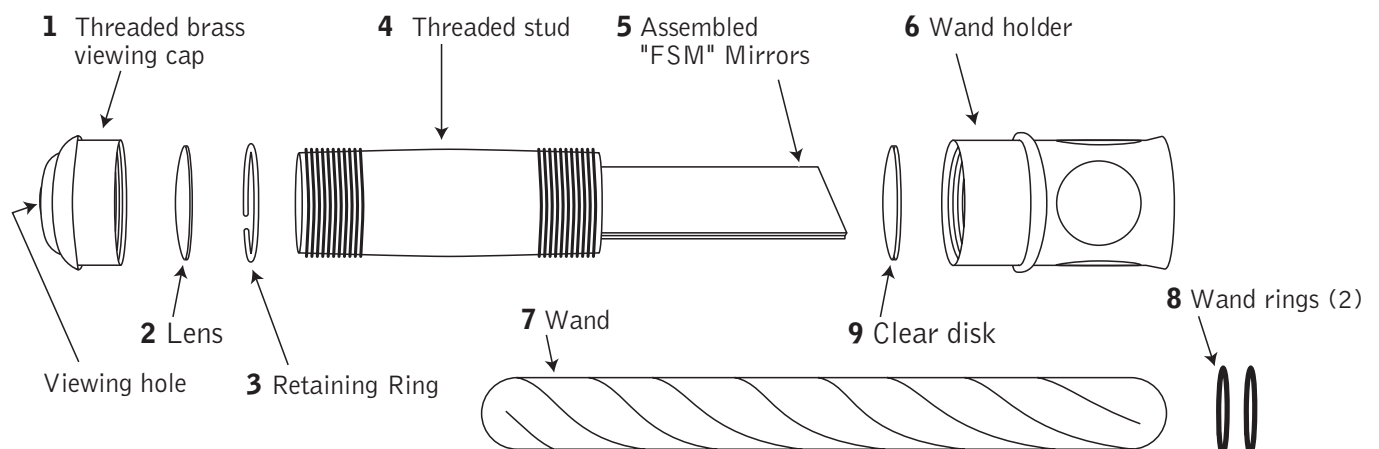

INSTALLING THE LENS IN THE VIEWING CAP

Position the viewing cap (#1) with the eyehole facing down. Drop the lens (#2) into the recess inside the cap with the convex side down, flat side up as shown. Place the lens retaining 'C' ring (#3) on top of the lens with the extending shoulder facing the lens as shown above.

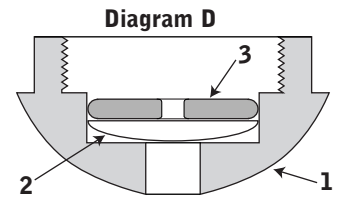

Viewing cap assembled with lens and retaining 'C' ring

ASSEMBLING AND INSTALLING THE F.S.M (FRONT SURFACE MIRROR)

Note: If the F.S.M. is already assembled, skip this step.

Lay down two pieces of tape about 1 1/2" long, sticky side up. (The front surface side of the mirror is covered with a protective plastic film) Remove the film and lay down the mirrors on the tape with the mirrored surface face up.

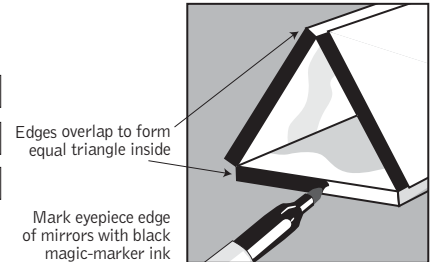
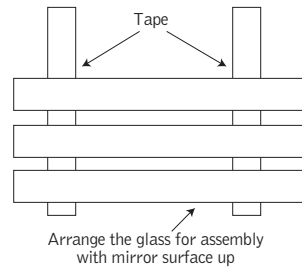

Diagram E

Space the mirrors 3/32" apart. Keep the mirrors parallel and edges aligned. Clean the mirror surfaces if necessary (with a glass cleaner) to eliminate any dirt or smudges.

Carefully fold the mirrors into a triangular tube with the mirrored sides facing inside. Wrap the tape securely around the mirror tube. The edges should meet as indicated in the figure above.

Insert the triangular mirror tube (#5) into the threaded brass stud (#4). The mirrors should fit snugly inside the tube. If the mirrors slide freely inside the tube, add tape around the mirrors until the mirror tube fits snugly.

FINAL ASSEMBLY

- Insert the clear disk (#9) into the threaded hole of the wand holder.
- Thread the brass stud (#4) (with the mirrors inside) into the wand holder (#6) making a tight fit against the clear disk (#9).
- Slide this assembly into the wooden barrel. Thread on the viewing cap assembly (#1,2,3) over the exposed thread on the opposite end, hand tight.
- Insert the wand (#7) through the holes in the holder to the middle. Slide the retaining 'o' rings (#8) one over each end of the wand to secure it from sliding out.
- The Wand Kaleidoscope is ready for viewing! For best results, aim towards a bright light source, and rotate while looking through the opening.

Diagram F: ASSEMBLED KAL-WAND KIT

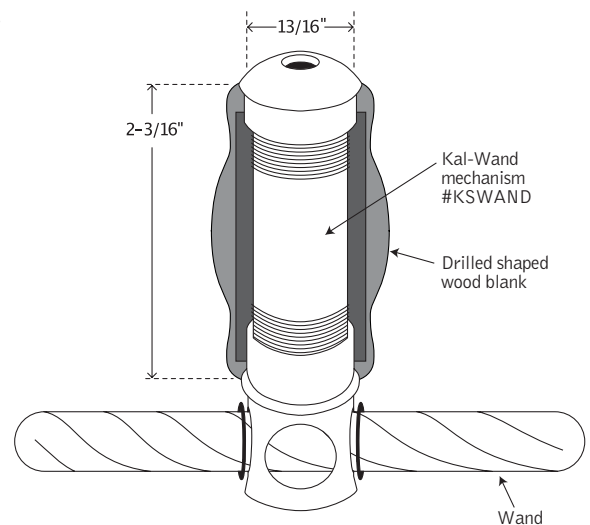

KALEIDOSCOPE WAND STANDS

The Kaleidoscope Wand can be presented in a variety of attractive formats. You can turn a small candlestick type of stand or use one of PSI's prefabricated stands shown here.



Diagram G

BUSHINGS #KSEG-M

