

DRILLCENT3 Self-Centering "Drilling Center" Vise Version 2 - Operating Instructions

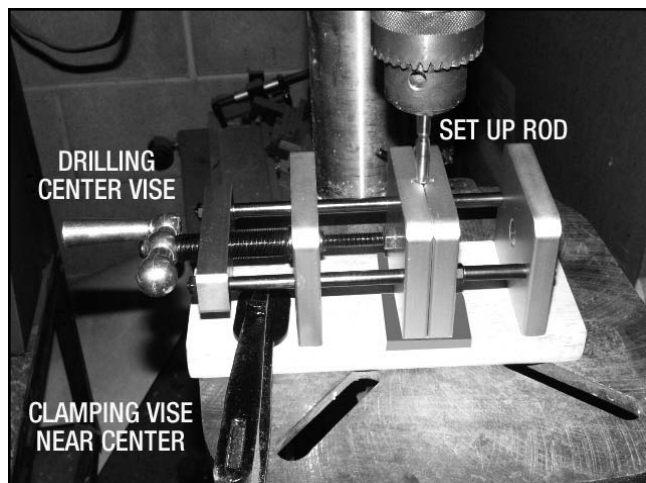

Clamping the Vise



Drilling the Blank

You have just received an improved and more efficient pen blank drilling vise available. Correctly used, our vise will consistently position your wood blank flawlessly for drilling holes through the exact center. The blanks can be any shape and be a maximum width of 2-1/4".

Set up for drilling (1-3/4" or smaller)

Place a rod, 3/8" or larger, in a drill press. If a rod is not available use a drill bit. Open the vise jaws and close the jaws with the rod gripped by the slots in the jaws. When centered, clamp the vise onto the drill press table (clamping nearer to the center works best). Adjust the drill press table, if necessary, for proper depth of cut.

Be sure the vise is flat and perpendicular to the drill press. Use a level if necessary.

Position Scrap Material

A channel is provided under the center jaws to allow a 2" wide x 1/4" thick scrap. Slide and flip the scrap material for a clean finish everytime you drill. We have provided a 2" x 6" x 1/4" piece with your jig. Cut your own strip once this is consumed.

Drilling the blank

Cut a blank to your desired length. The blank should be centered exactly. Insert the blank into the vise jaw slots, and lowered onto the wood scrap; close jaws tightly. You are also able to change the bits or blanks as necessary without re-centering the vise.