

Super Cartridge Filter

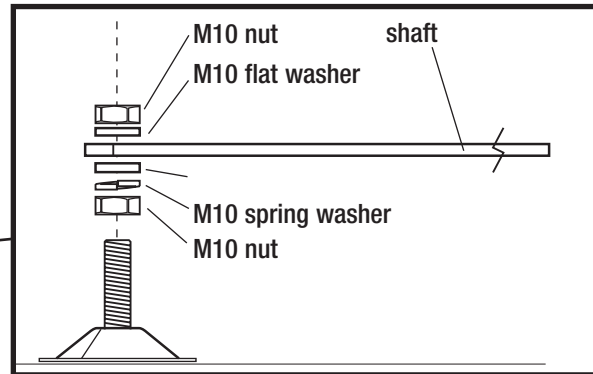
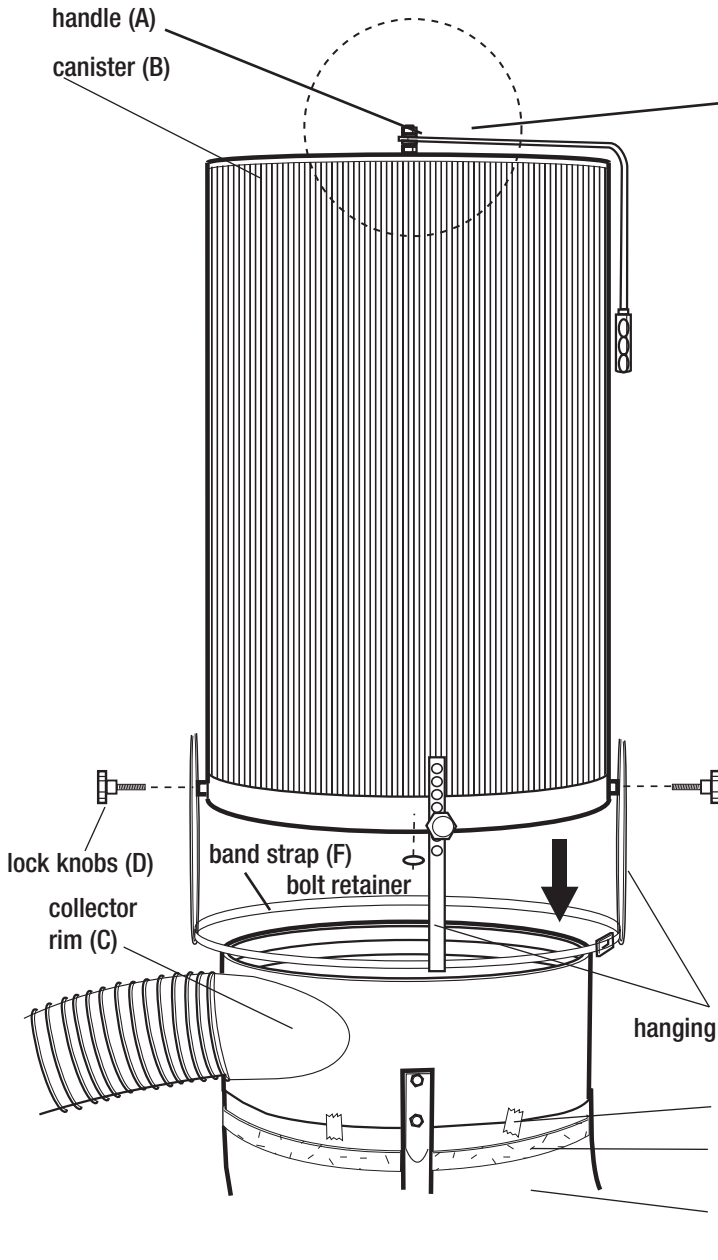

Fig. 1 Handle assembly.

Instructions

1. Turning the handle (A) should rotate the wiper inside the canister.
2. Mount canister (B) on top of collector rim (C), making sure the filter sits uniformly and securely around the edge.
3. Mount hanging straps (G) on lock knobs (D) as shown. Position in appropriate hole so that band clamp (F) connects at the bottom of collector rim (C).
4. Press down on the canister as you tighten the lock knobs (D) around the rim of the collector.
5. Thread the band clamp (F) through the hanging straps (G).
6. Apply sealer foam (H) around the rim as shown.
7. Using the push nut bolt retainer (included separately) place over end of center rod (flapper rod) once through the hole in center of canister bracket and lightly tap with hammer to secure bolt retainer into place.
8. Use adhesive tape to position the trash bag (E) prior to clamping.
9. Secure the trash bag with the large band clamp (F). The clamp should grip the bag at the foam to seal and prevent air leakage.
10. Clean the canister daily by rotating the wiper. You can also blow out the dust at low air pressure (30 psi) using an air compressor or use the blower end of a shop vacuum.