

**KIT FEATURES**

- Attractive for car and wine enthusiast
- A realistic gearshift disc
- Heavy chrome plating to resist corrosion

**REQUIRED ACCESSORIES**

- 7mm pen mandrel
- 7mm drill bit #PK-7MM
- 2pc bushing set #BS11GSBU
- 7mm barrel trimmer #PK-TRIM7
- 7/8" Forstner Bit #FB78
- 2-part epoxy or insta-cure (cyanoacrylate) glue

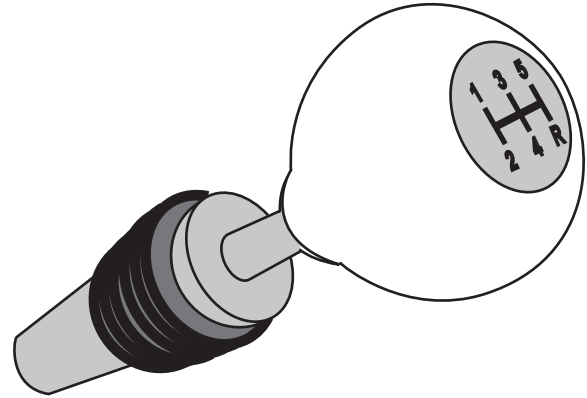

**DIAGRAM A – PARTS LIST**

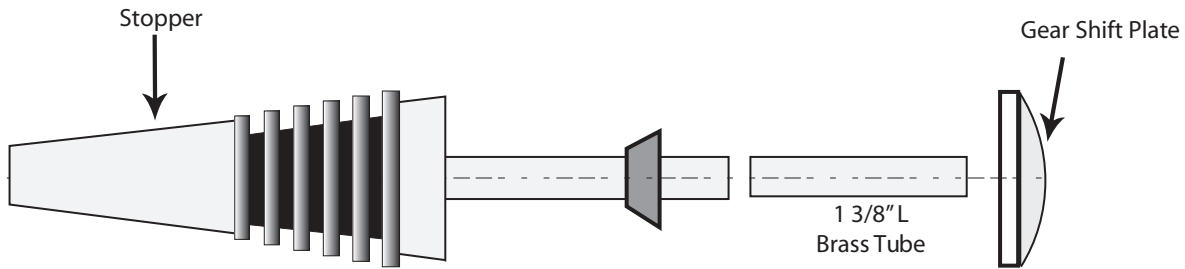

**PREPARING THE BLANK**

- Prepare a blank about 1-3/4" square, 1-5/8" long. Mark the center of the flat surface. Drill a 7/8" forstner bit hole to 3/32" deep (Test depth with the gearshift disc). Drill a 7mm hole; follow the center of the forstner bit through the blank.
- Glue the tube into the blank from the opposite end of the recessed end. Stop at the bottom of the recess.
- Use a 7mm barrel trimmer to square the end of the blank, trim to the brass tube.

**DIAGRAM B**

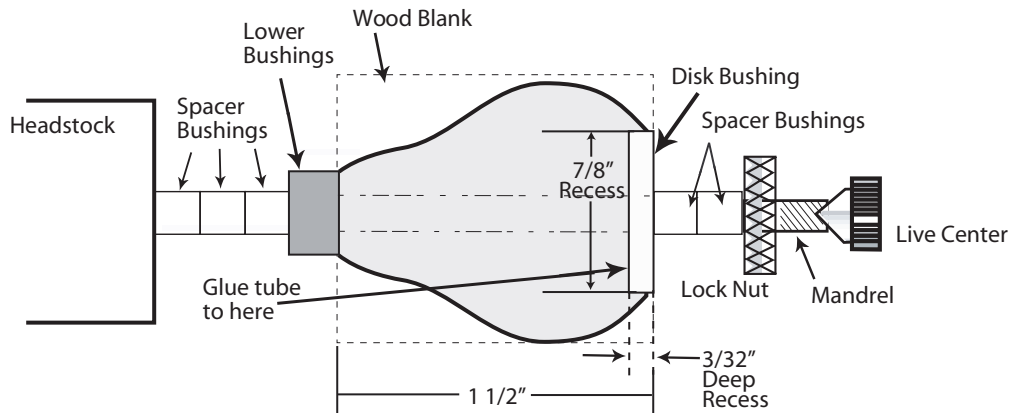

**TURNING THE BLANK**

- Insert spacer bushings on the mandrel shaft. Follow with the lower bushing. Insert the blank, non-recessed end in first. Follow with the disc bushing into the recess. Add spacer bushings to close the space to the threads. Mount the lock nut. Bring the tailstock in for support. Lock the set up in place.
- Turn the wood to a shape of an automotive gearshift. Turn from bushing to bushing to shape the wood. For best results try to follow and match the curve of the gearshift disc.
- Sand and finish with high gloss, CA formula is recommended.

**DIAGRAM C**

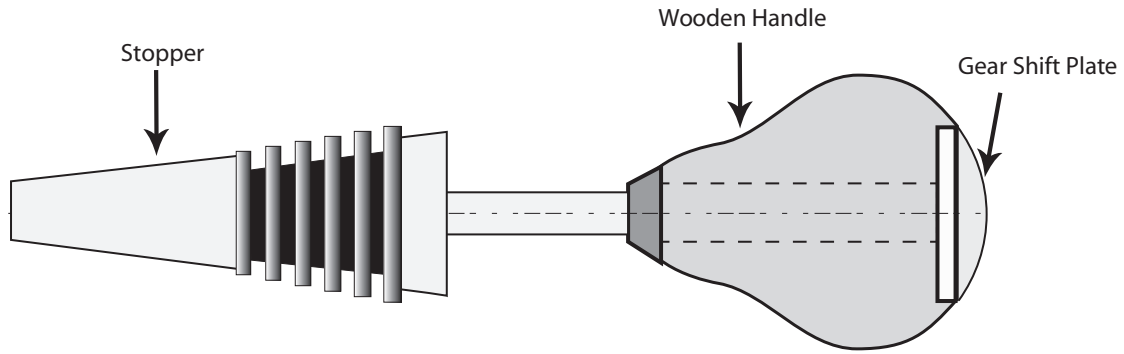

**ASSEMBLY**

- Squeeze glue into the bottom (narrow) recess. Press the stopper shaft into the bottom..
- Glue and insert the gearshift disc into the top recess. Let dry.

**DIAGRAM D  
BUSHINGS – BS11GSBU**

