

# PSI Tempest Stand Assembly Instructions Rev.2

## Item # TEMPSTAND

Parts List			
Key	Description	Size	Qty
1	Lower vertical support member		4
2	Side and Back base members		3
3	Front top support member		2
4	Cyclone support member		4
5	Angle support member		2
6	Back top support member		2
7	Hex head bolt	M10x50	4
8	Flat washer	M10	8
9	Nut	M10	4
10	Flat Washer	M8	48
11	Nut	M8	48
12	Carriage Bolt	M8x16	48
13	Front base flat member		1
14	Spring Washer	M8	48
15	Spring Washer	M10	4

Secure the plywood back to the back top support member (key #6) with the bolts supplied (key#7)

To mount the motor/blower to the stand - lay the stand down with the back on the floor. Insert the cyclone into its support, then position the blower on top. Mark the mounting holes, then secure the motor/blower to the plywood back.

User supplied plywood back 24-1/4" x 36". Use 5/8", 1" or 3/4" plywood for this part and for the cyclone support below. (You will need to cut a shim to take up the gap between the motor bracket and the back. This thickness will vary from 3/4" to 2", depending on the motor and the hole location.)

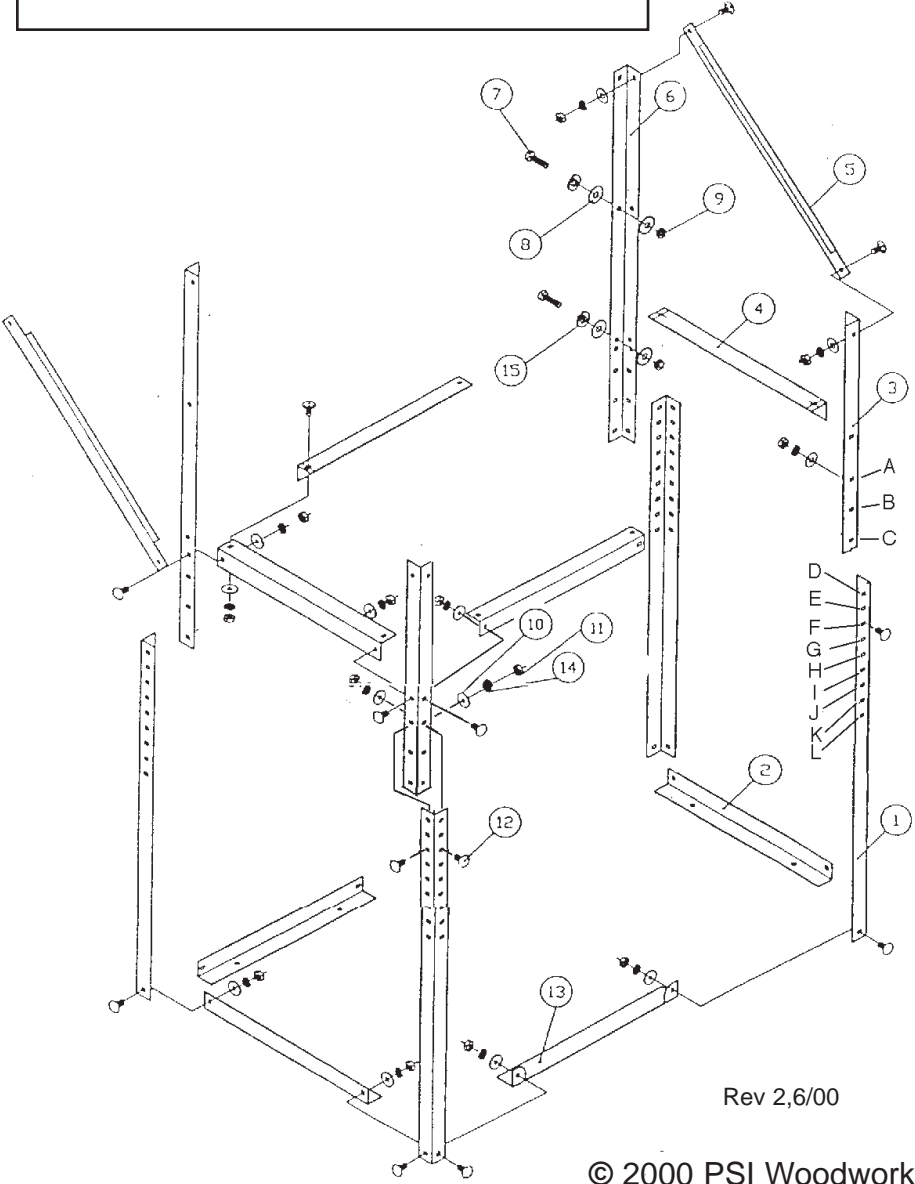
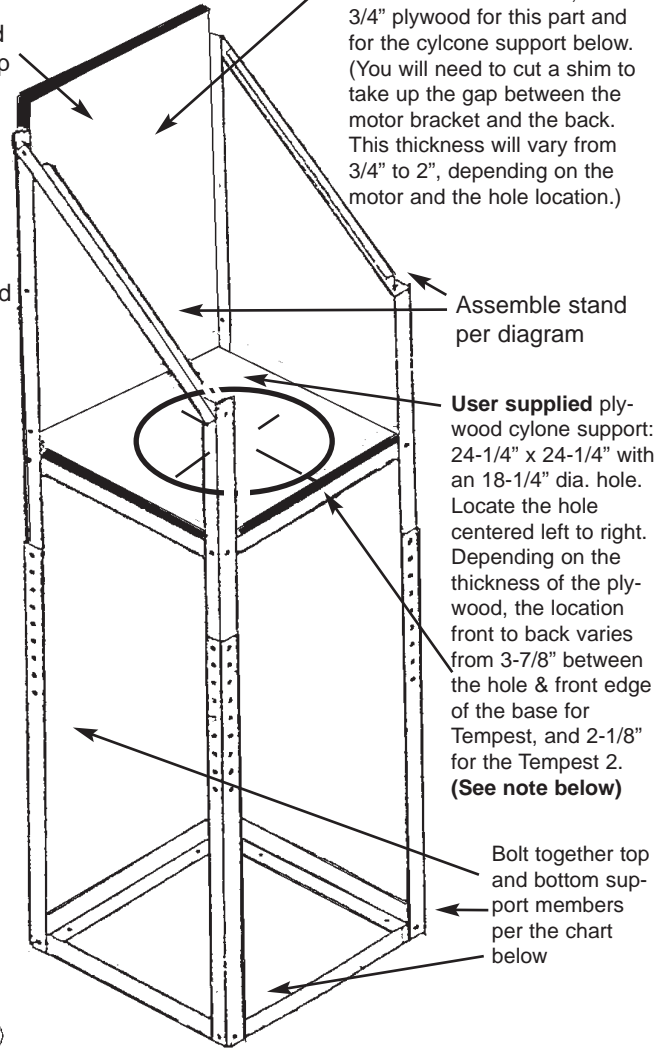

### Variable Height Feature

Bolt the bottom member holes indicated in the chart through the top member holes on the left in order to accommodate container heights indicated:

Top Member Hole #	Trash Container Height							
	21"	23"	25"	27"	29"	31"	33"	35"
A	I	H	G	F	E	D	-	-
B	K	J	I	H	G	F	E	D
C	-	L	K	J	I	H	G	F
\----- Bottom Member Hole # -----/								

**Note:** You may cut the support piece 1" smaller (24-1/2" x 23-1/2") to allow for front-to-back adjustment, thus eliminating additional shims.

Rev 2,6/00