

ITEM# PKTOP2
Ball Bearing Spinning Top Kit

KIT FEATURES

- 24 kt gold plated parts
- Independent ball bearing allows spinning on most surfaces
- Low friction, plastic spinning tip
- 20" long pull string
- Turned on a mandrel: easy to make, precision balanced for longer spin time.

REQUIRED ACCESSORIES

- 7-mm, long mandrel
- 2 piece bushing #PK10-BUSH3 or PKPAR 10-B2 (use only 2 of the 3 bushing set)
- 10-mm drill bit #PK10-10
- 10-mm barrel trimmer #PK-TRIM10
- 2 part epoxy glue, polyurethane or insta-cure (cyanoacrylate) glue.

Diagram A - Parts list

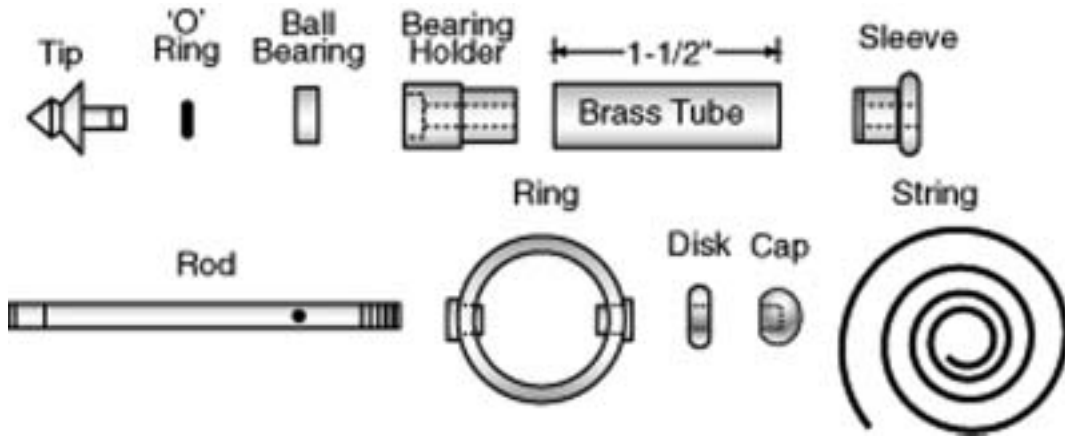

PREPARING THE BLANK

- Cut a blank to 1-1/2" long x 2-1/4" to 2-1/2" square
- Mark the center of the blank and drill a 10-mm hole length-wise through the blank. (You may saw off the corners to ease the turning process.)

Use a liberal amount of glue and spread over the brass tube. Insert into the hole with a twisting motion to spread the glue evenly inside. When dried use the Barrel Trimmer to square the ends.

Diagram B - Turning the Blank

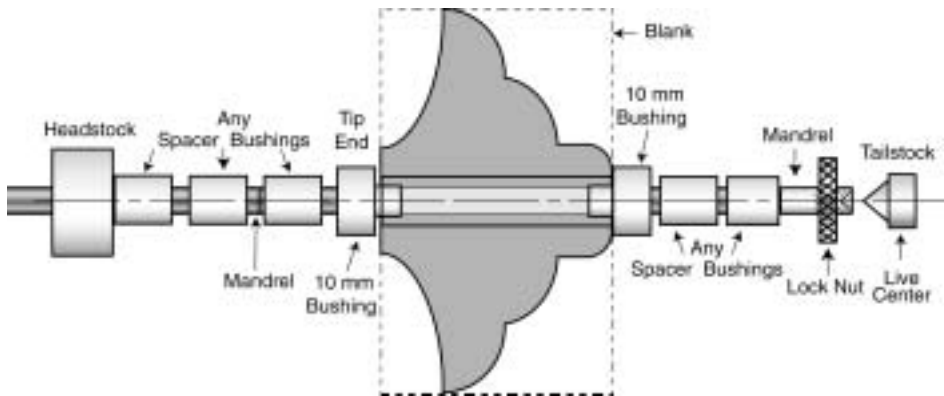

IMPORTANT – The mass of your turned top must be distributed as much as possible to the outer rim! Profiles should be configured to look like a “flying saucer”. Tops with diameters of 2-1/2" and up will tend to perform best. Some appropriate profiles are shown in Diagram D. Heavier, denser woods can have a smaller diameter (2-1/4") than lighter woods (2-1/2"+).

TURNING THE BLANK

- Design or choose a suggested profile from the Diagram D.
- Mount spacer bushings onto the mandrel shaft to bring the blank away from the headstock. Slide a 10 mm bushing onto the mandrel shaft, wide end first. Mount the blank over the stepped bushing; follow with the other bushing narrow end in first. Fill in the remaining space on the mandrel with other bushings or spacers. Thread on the lock nut hand

- tight. Bring the tailstock in snug against the shaft. Lock in place.
- Tighten the Lock Nut. Do not over tighten, it may damage the mandrel.
- Use lathe chisels to turn the wood down to the desired profile. Keep a diameter to 2-1/4" or larger.
- Sand and finish the wood. Use friction polish or brush on PSI clear hi-gloss #HGPF lacquer. Finish off the lathe.

Diagram C - Assembly

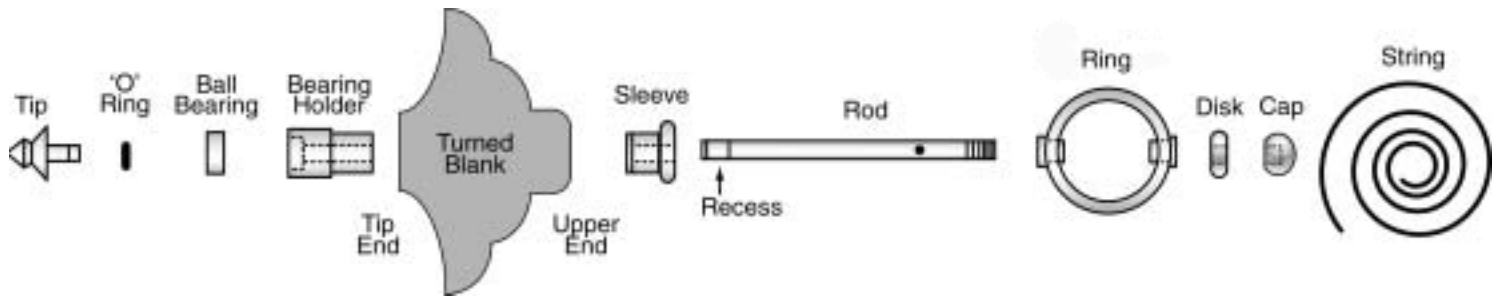

ASSEMBLY

- Line up turned wood and top components according to Diagram C.
- Press the ball bearing into the space in the bearing holder.
- Press the bearing holder, narrow end in first, into the tip end of the blank until it is flush with the outer surface of the blank.
- Press the sleeve, narrow end in first into the opposite end of the blank.
- Position the rod with the threaded end towards the upper part of the top. Insert the rod through the sleeve and into the bearing holder at the bottom (as shown). Press into the bearing holder. (Be sure recess is in the holder hole before pressing.)
- Slide the Brass Ring over the rod. The string hole on the rod will be at the center of the ring.
- Thread the disk over the rod to the plastic bushing.
- Thread the cap tightly to the end.
- Slip the tiny 'O' ring onto the shaft of the spinning tip. Slide into the slot.
- Push the tip into the hole of the bearing until it clicks in firmly. Be sure tip spins freely.
- Make a knot at one end of the string. Thread the other end through the hole in the rod. Make a knot at the other end to keep the string from sliding out.

OPERATING THE SPINNING TOP

To operate and spin the top, hold the Brass Ring between your fingers. While holding, spin the wooden body until string wraps around the rod. Now, while still holding the ring in your hand, pull the string and release immediately. The top will spin fast. While base is spinning in your hand, let go of the ring over any surface and the top will spin freely. Enjoy watching your handcrafted top spin!

Bushings

#PKPARK-BU2

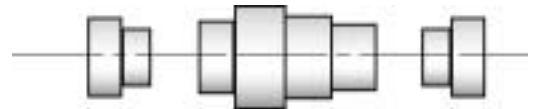

#PK10-BUSH3

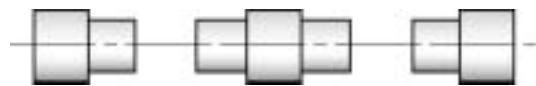

Diagram D - Suggested Spinning Top Profiles 2-1/2" Diameter X 1-1/2" High

