

Model #PKPURSE Purse Pen Kit

Kit Features:

- Heavy 24 kt. Gold Plating with Epoxy Coating.
- Construction features a smooth click cap that fits over the tail end when in use.
- Mini design to fit into purse.
- Assemble with or without the clip, for purse or pocket use.
- Uses mini pen refill #PKMINI-RS (R) black or red ink.
- Overall Length: 4-7/16" (closed).

Required Accessories:

- 7mm, Long Mandrel.
- 3 Pc. Bushing Set #PKPURSE-BU.
- 3/8" Drill Bit #PKEXEC-3/8.
- 8mm Barrel Trimmer #PK-TRIM8 (optional with 8mm tube).
- 2 Part Epoxy Glue, Polyurathane Glue, or Insta-Cure (cyanoacrylate).

Diagram A / Parts Layout

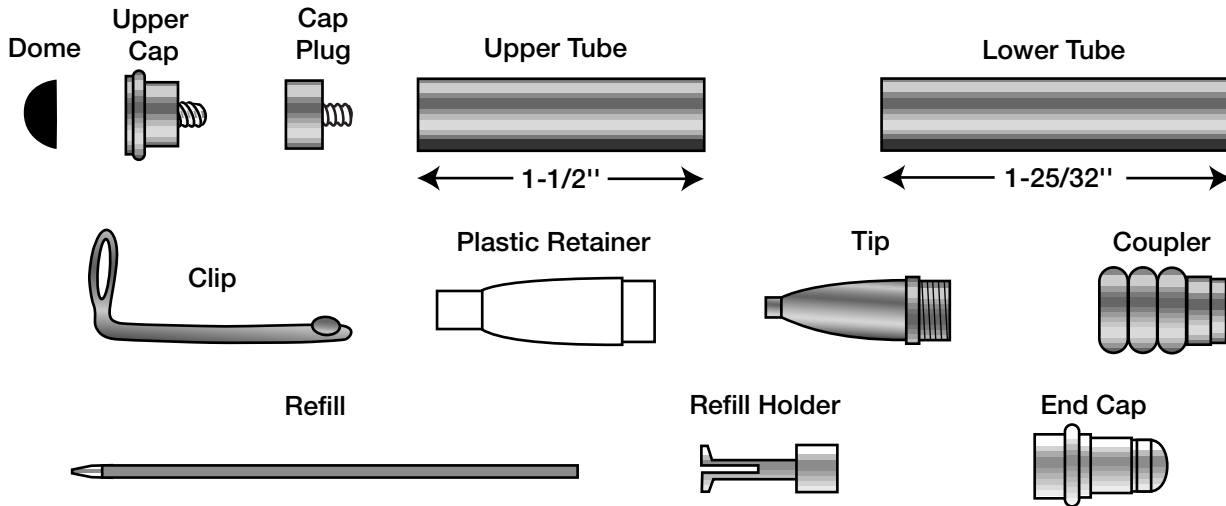

Preparing the Blanks

- Cut a 5/8" square blank to the length of the brass tube (add 1/16" for squaring off).
- Drill a 3/8" center hole lengthwise through each blank.
- Spread glue over tube. Insert the tube into the blank with a twisting motion to spread the glue evenly inside.

Center each tube lengthwise in the blank.

- When the glue dries, square the ends of the blanks. Use an 8mm barrel trimmer with an 8mm tube as a sleeve over the shaft or a belt/disc sander. Trim the wood down flush to the end of the brass tubes.

Diagram B / Turning The Blanks

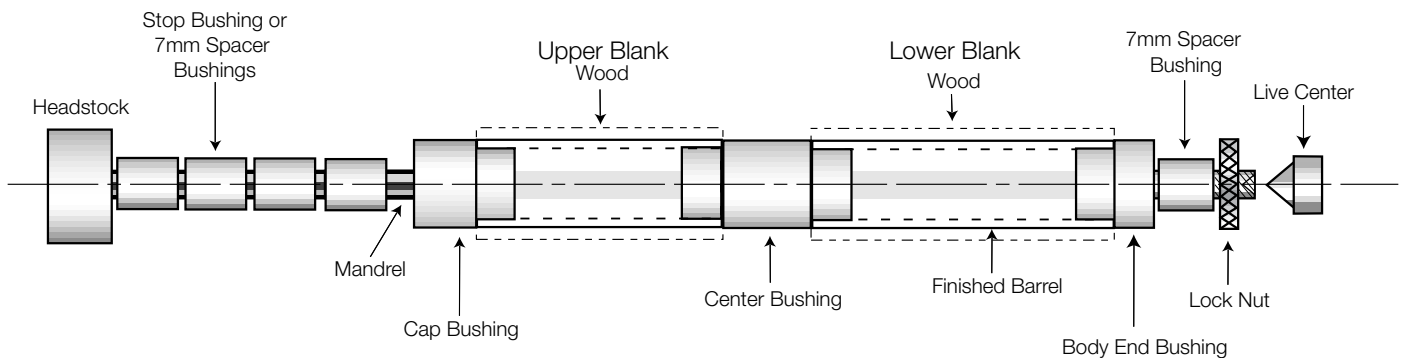

Turning the Blanks

- Place the stop bushing onto the mandrel, or use 4 or 5, 7mm bushings. Place the larger cap bushing wide end in first. Slide on the shorter blank. Place the center bushing on the mandrel. Slide on the longer blank and follow with the body end bushing, narrow dia. first. Thread on the lock nut hand tight. Bring the tail stock snug with the mandrel. (Do not overtighten, it could damage the mandrel). Slide the stop bushing (if used) toward the blank

(or use additional bushings) adjusting to remove spaces. Then tighten the set screw and tighten the lock nut hand tight.

- Turn the wood down, flush with the bushings using a lathe chisel and gradual higher grits of sand paper.
- Sand both blanks, finish the blanks with your choice of polish and waxes. Friction polish and waxes are available from PSI.

Diagram C / Assembly

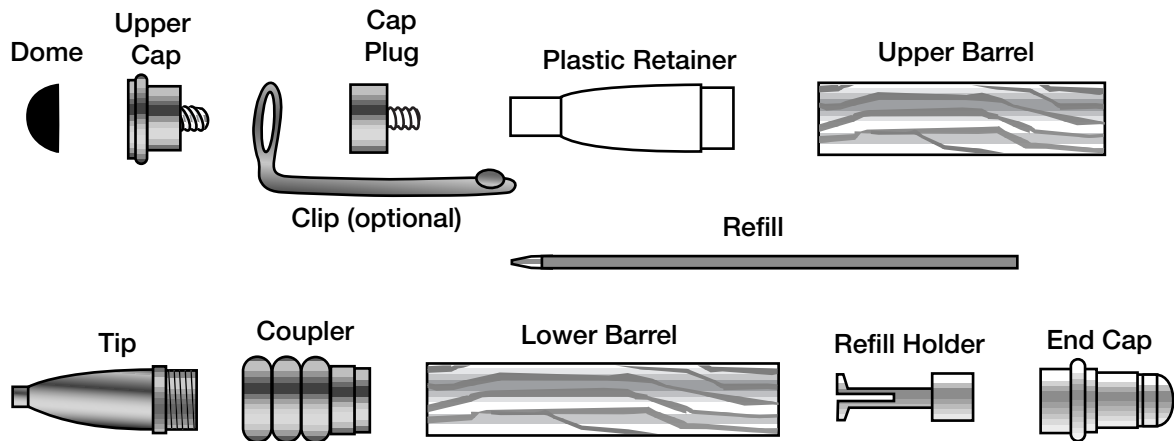

Assembly Tips

- Line up the finished parts according to diagram "C".
- To assemble the parts, use a vise or a clamping instrument with wooden jaws. Press slowly with caution, keep the parts aligned to avoid cracking the wood or scratching the gold plating.
- You may choose to assemble pen with the clip or without the clip.

Upper Barrel

- Insert the upper cap into the clip. Screw the cap plug, wide end first, over the upper cap.
- Hand thread the plastic retainer's, small opening over the thread on the cap plug to the bottom.
- Insert this assembly into the upper barrel and press flush to the clip base.

- Use a drop of glue to attach the black plastic dome to the upper cap top.

Lower Barrel

- Use a drop of glue in the hole of the end cap. Insert the refill holder (wide end) into the hole, let set.
- Press this assembly into the lower barrel.
- Press the coupler into the opposite end of the lower barrel.
- Insert a mini refill inside the coupler into the refill holder, secure inside the slot.
- Thread the tip into the coupler and tighten. The refill tip will be exposed and ready to use.
- Place the upper cap over the tip until it clicks.

Bushings (#PKPURSE-BU)

