

Classic Parker® Style Twist Pencil Kit

Kit Features:

- Heavy 24 kt. Gold Plating with Epoxy Coating.
- Pencil Construction is Similar in Appearance to the Classic Parker® Pen of the 1920's.
- Overall Length: 5-3/8".
- Heavy duty .7mm lead.
- Designed to match PSI classic "Parker®" pen series.

Required Accessories:

- 7mm, Long Mandrel.
- 3 Pc. Bushing Set #PKPARK-BU3.
- 8mm Drill Bit #PKPARK-8MM.
- 7mm Barrel Trimmer #PK-TRIM (optional) with 7mm tube.
- 2 Part Epoxy Glue, Polyurathane Glue, or Insta-Cure (cyanoacrylate glue).

Diagram A / Parts Layout

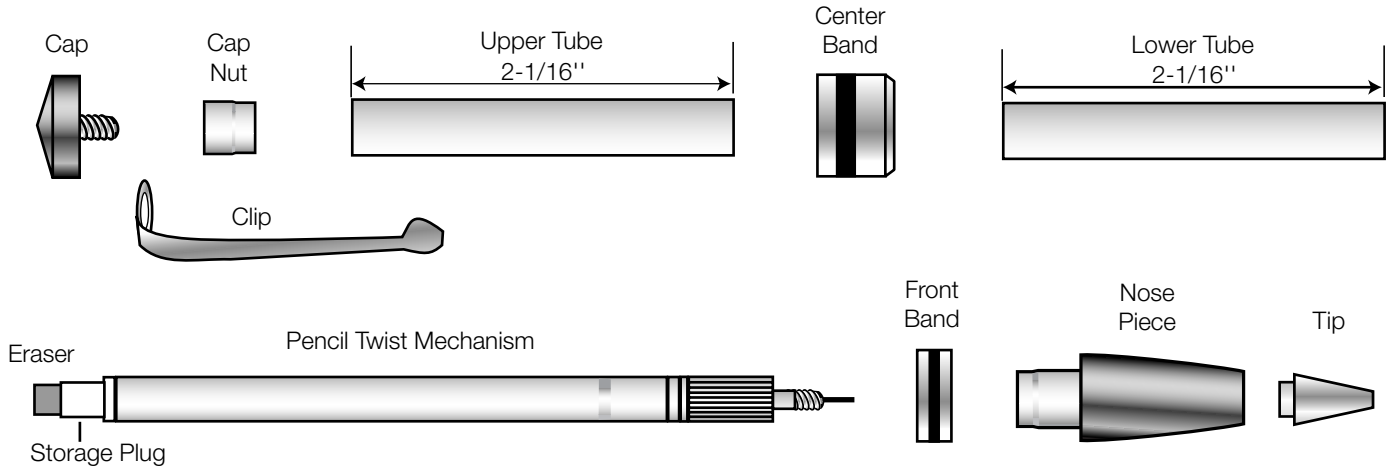

Preparing the Blanks

- Cut 3/4" to 5/8" square blanks to the length of the brass tubes (add 1/16" for squaring off).
- Drill an 8mm center hole lengthwise through each blank.
- Spread glue over tube. Insert the tube into the blank with a twisting motion to spread the glue evenly inside.

Center each tube lengthwise in the blanks.

- When the glue dries, square the ends of the blanks. Use a 7mm barrel trimmer with a 7mm tube as a sleeve over the shaft, or use a belt/disc sander. Trim the wood down flush to the end of the brass tubes.

Diagram B / Turning The Blanks

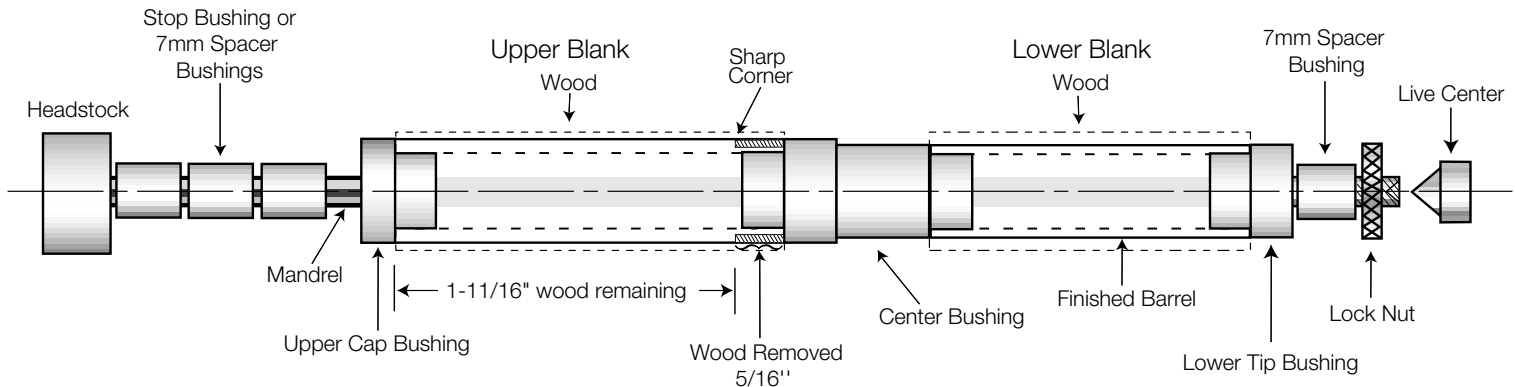

Turning the Blanks

- Place the stop bushing onto the mandrel hand tight, or use 2 or 3, 7mm bushings. Place the cap bushing (large dia.) wide end first. Then slide on either blank. Place the center bushing (wide end first) on the mandrel. Slide on the other blank and follow with the tip bushing, narrow diameter first. Thread on the lock nut hand tight. Bring the tail stock snug with the mandrel. (Do not overtighten, it could damage the mandrel).

Slide the stop bushing (if used) toward the blank adjusting to remove spaces. Then tighten the set screw and tighten the lock nut.

- Turn the wood down, flush with the bushings using a lathe chisel and gradual higher grits of sand paper. Final sand both blanks for later finishing.

For the next step, you must remove the tip bushing and the lower blank from the mandrel and turn the center bushing around 180 degrees, then re-mount the bushings and lower blank.

been turned around 180 degrees, and there is a smaller diameter against the wood). Be careful, you must retain a sharp 90° corner at the end of the upper blank when you remove the excess wood.

Removing Wood for the Center Band by Making a Tenon

- With a pencil, mark 1-3/4" from the upper cap bushing on the upper barrel. Use a parting tool to remove the excess wood down flush to the outside diameter of the center bushing. (note that the center bushing has now

- Remove the tip bushing, lower blank, and the center bushing from the mandrel to test the fit of the center band on the tenon. If no rework is needed, continue.
- Finish the blanks with your choice of polish and waxes. Friction polish and waxes are available from PSI.

Diagram C - Assembly

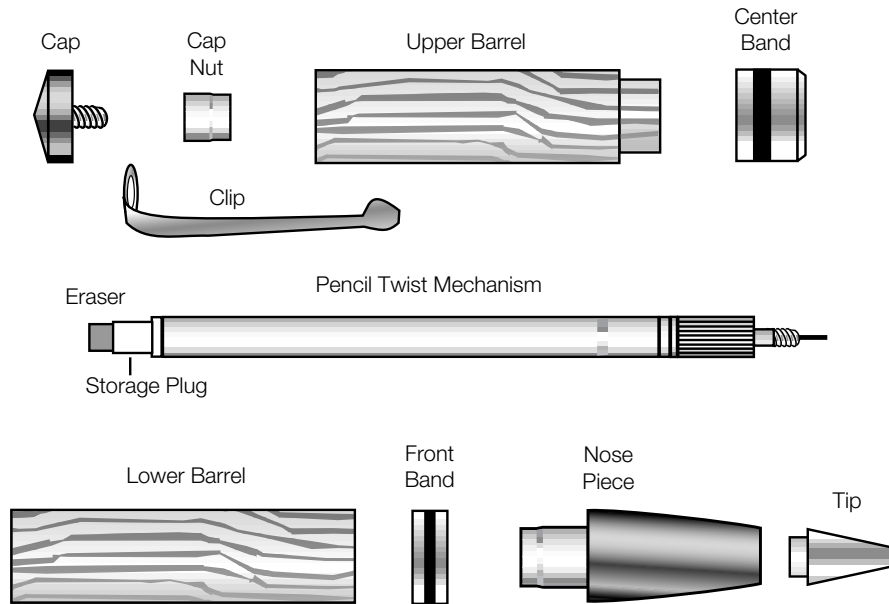

Assembly

- Line up the finished parts according to diagram "C".
- To assemble the parts, use a vise or a clamping instrument with wooden jaws. Press slowly with caution, keep the parts aligned to avoid cracking the wood or scratching the gold plating.

Upper Barrel

- Press the cap nut, recessed end first, into the flat end of the upper barrel.
- Use a drop of glue on the tenon and slide the center band (square end first) onto the upper barrel. Press together. Let dry. (Parts must be flush together with no gaps).
- Insert the cap screw into the clip. Use a drop of glue on the thread, and quickly screw it into the cap nut hand tight.

Lower Barrel

- Slide the front band over the nose piece extension, then press this assembly into the lower barrel.

- Insert the pencil mechanism into the opposite end, push in.
- Thread the tip onto nose piece engaging the mechanism extension. Screw on hand tight.
- Engage upper and lower completed barrels together.
- Pencil operates by twisting the ends to extend or retract the lead.

To Insert New Lead:

- Pull the pencil halves apart.
- Unscrew the tip from the nose piece.
- Turn the pencil mechanism clockwise until the guide pin is exposed at the end of the tip.
- Back-up the mechanism enough to pull the guide pin back inside the sleeve by 1/16".
- Insert the new lead in the hole and twist the mechanism counter-clockwise to retract the entire lead.
- Reassemble the Pencil.

Bushings (#PKPARK-BU3)

