

Fancy Necklace Pen Kit (Click Closure)

Kit Features:

- Easy to turn with straight tubes
- Convenient for working woman
- Attractive chain - 27" Long
- Minimum parts - easy to assemble
- Available in multiple finishes
- Uses Parker® Style Refill
- Easy click closure

Required Accessories:

- 7mm Pen Mandrel
- Drill Bit(s): 8mm #PKPARK-8MM & 11mm #PKPARK-11MM
- Bushing set(3 pc): #PKMAGNECBU
- Live Tailstock Center
- 2 Part Epoxy Glue or Insta Cure (Cyanoacrylate) Glue
- Pen Blank: Minimum Size - 3/4" x 3-1/2"



DIAGRAM A / PARTS LAYOUT

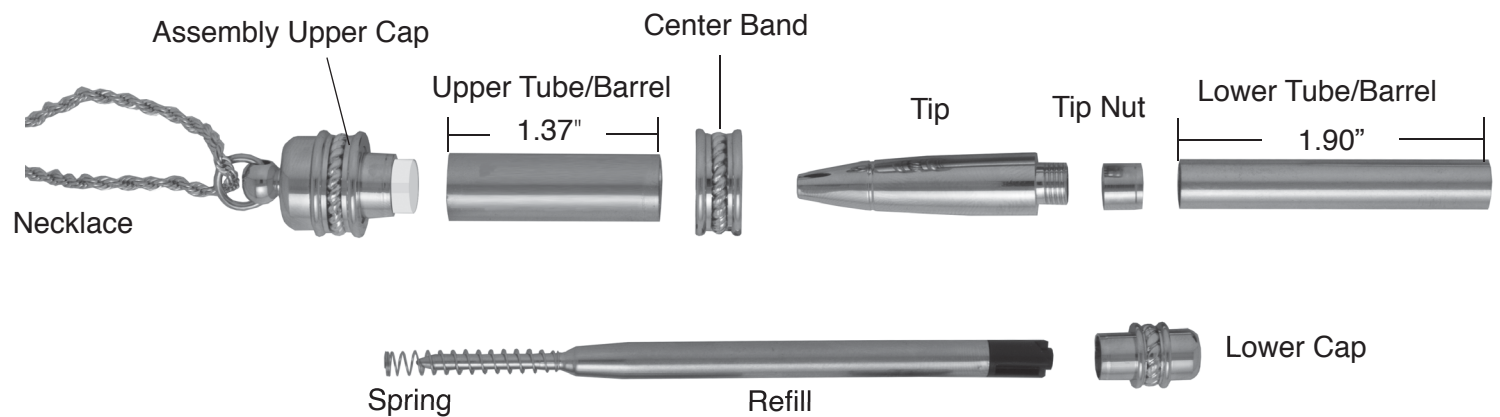

Preparing the Blank:

- Cut 2 blanks to the length of the tube(s) and add 1/16" for squaring off.
- Drill an 11mm hole lengthwise through the upper blank and an 8mm hole through the lower blank.
- Spread glue over the tube(s), insert the blank with a twisting motion to spread the glue evenly inside.
- Center the tubes lengthwise inside the blanks.
- When the glue is dry, square the ends of the blanks. Use a 7mm barrel trimmer with 11mm sleeve for the upper barrel and an 8mm trimmer for the lower blank, or a universal pen blank squaring jig with a power disc sander. Take the excess material down flush with the ends of the brass tube. (Do not trim beyond the length of the tube since this may interfere with operation of the mechanism and assembly). Use a barrel trimmer to clean the inside of the tube.

DIAGRAM B / TURNING THE BLANKS

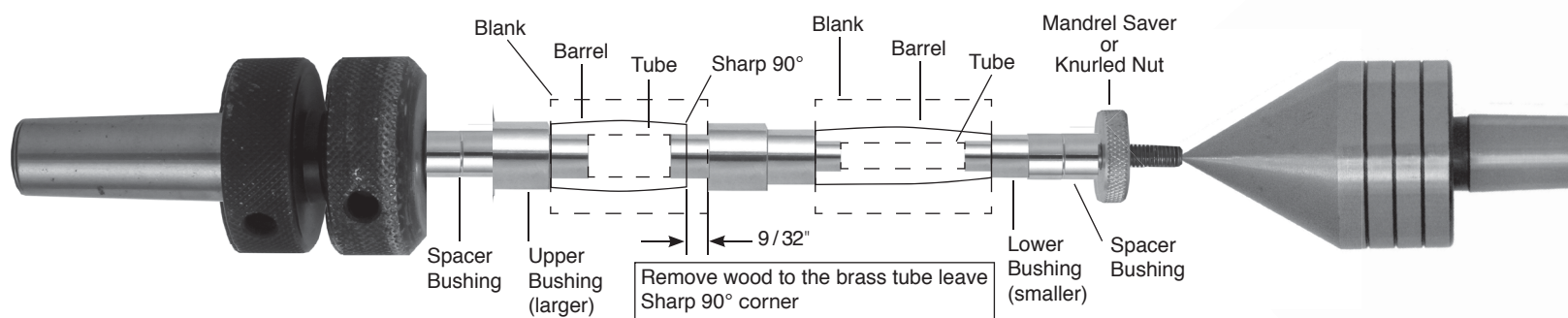
**Turning the Blank**

- Mount the bushings and blanks according to diagram B.
- Thread on the knurled nut and hand tighten to hold all components in place.
- Slide the tailstock up snugly against the mandrel shaft inserting the live center point into the mandrel dimple, lock in place.
- Hand tighten the quill adjustment to firm up the mandrel. (DO NOT overtighten, it could damage the mandrel.)
- Using sharp tools, turn the blank down close to the bushing diameter. Turn the barrels to a profile.
- Use a parting tool, remove 9/32" wood to the brass tube. See Dia. 'B'
- Sand the blank down to be flush with the bushings gradually increasing the sandpaper grits.
- Finish the barrel with your choice of polish. Allow sufficient time for the polish to cure.
Refer to polish instructions.

Assembly

- Layout parts according to diagram A
- Press the upper cap assembly into the solid end of the upper barrel.
- Affix the band into the recessed end of the upper tube and press in to close the gap to the wood.
- Press the tip nut, recessed end in first into the wider end of the lower barrel.
- Press the lower cap into the opposite end of the barrel.
- Affix the spring over the refill tip, drop the refill into the opening at the coupler nut.
- Screw the tip over the refill.
- The pen is ready to use.
- To complete the closure, insert the lower end into the upper end until you hear the closure click.
- Insert the chain into the ring at the cap to use the pen as a necklace.

Diagram C / Bushings #PKMAGNECBU