

# BULLET CARTRIDGE CLICK Pen Kit

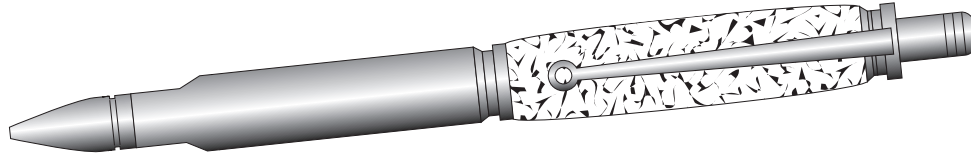

## KIT FEATURES

- Replicates an actual 30-caliber shell casing
- Click-type mechanism
- Bull's-Eye Clip Style
- Uses Parker™ style refill (Gel Compatible)
- Overall length is 5-5/8"

## REQUIRED ACCESSORIES

- 7mm, Pen Mandrel
- 8mm Drill Bit #PKPARK-8mm
- 2-piece Bushing Set #PKCP2400BU
- Universal Barrel Trimmer system #PKTRIMKIT (Use 8mm Shaft)
- 2-part epoxy glue or Insta-cure (cyano acrylate) glue

DIAGRAM A • Parts

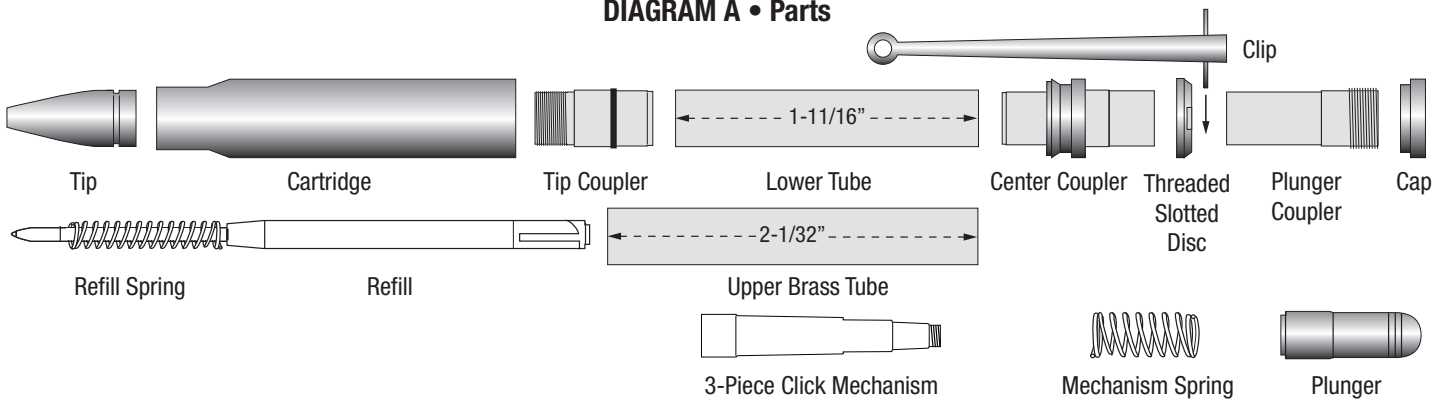

## PREPARING THE BLANK

- Cut 5/8" square blank to the size of the Upper Brass Tube. Add 1/16" to each end for squaring off.
- Drill an 8mm hole through the center of the blank.
- Apply glue to the tube and insert it into the blank with a twisting motion to spread the glue evenly. Center the tube within the blank and allow to dry.
- Use a barrel trimmer (#PKTRIMKIT) to square the ends of the blank to the brass tube.

## TURNING THE BLANK

- Place spacer bushings on the mandrel. Place one end bushing on, followed by the prepared blank.
- Assemble the second end bushing. Follow with additional spacer bushings as needed.
- Thread the lock nut hand tight onto the mandrel. Do not overtighten, it could damage the mandrel.
- Bring tailstock snug to the mandrel and lock it into place. Tighten the lock nut for turning.
- Using sharp tools, turn the blank down and sand it to the size of the end bushings.
- Finish the blank with your choice of polish.

DIAGRAM B • Turning The Blank

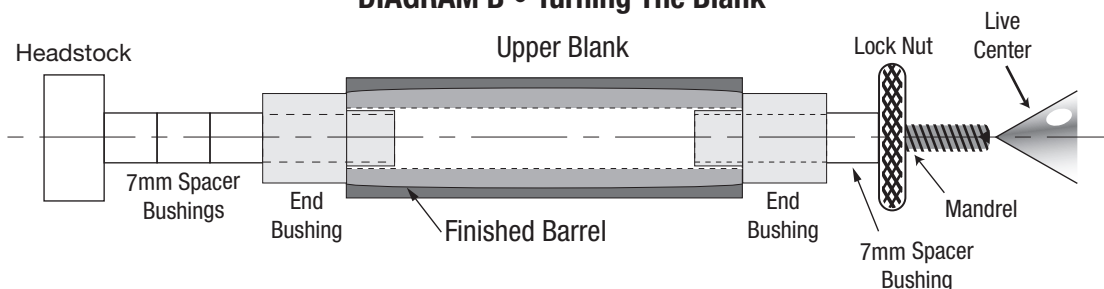

**ASSEMBLY**

- Line up the pen parts according to **DIAGRAM C**.
- Press the tip coupler into the lower tube to the shoulder.
- Slide this assembly, threaded end first, through the rear of the cartridge to expose the threads.
- Screw the tip onto the tip coupler. Hand tighten to the end.
- Insert the center coupler, short extension in first, into the lower tube at the cartridge. Press into the shoulder, no further.
- Insert the 3-piece mechanism, threaded end in first, into the opening of the upper barrel.
- Press the barrel, same opening, over the opposite, long extension of the center coupler.
- Press the plunger coupler into the opposite end of the barrel.
- Screw in the threaded slotted disc, slot towards the top, over the threads of the plunger coupler.
- Mount the clip, lined up with the slot, screw on the cap, small diameter in first. Tighten.
- Insert the mechanism spring through the plunger coupler. Screw the plunger into the threads of the mechanism stem over the spring. Unscrew the tip.
- Remove the protective cap off the refill tip. Insert the refill into the opening at the tip, wide end first with spring mounted. Screw the tip back on the tip coupler.
- The pen is ready to operate by clicking on the plunger to extract or retract the refill tip.

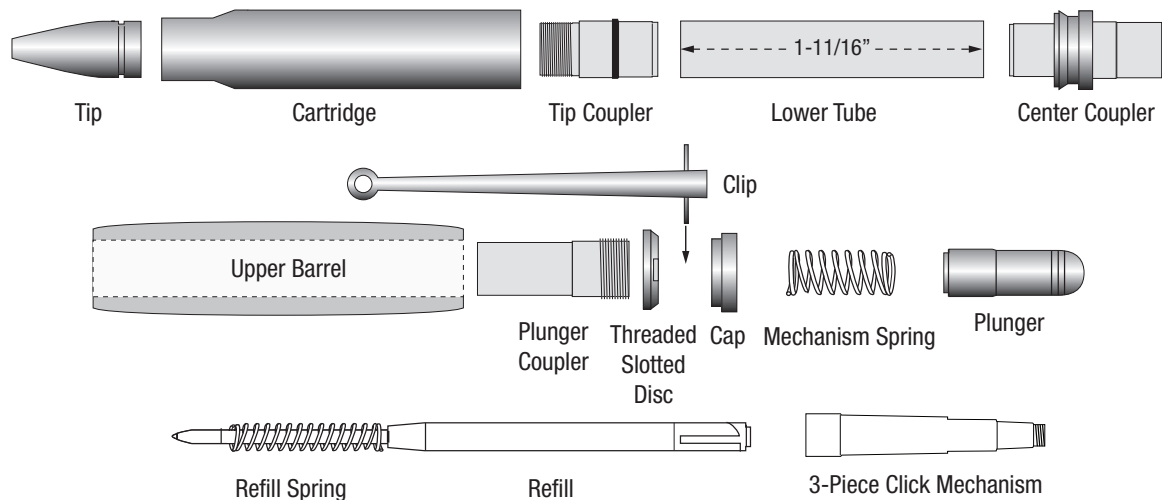
**DIAGRAM C • Assembly****BUSHINGS****DIAGRAM D • PKCP2400BU**