

OWNER'S OPERATING MANUAL

DUST COLLECTOR

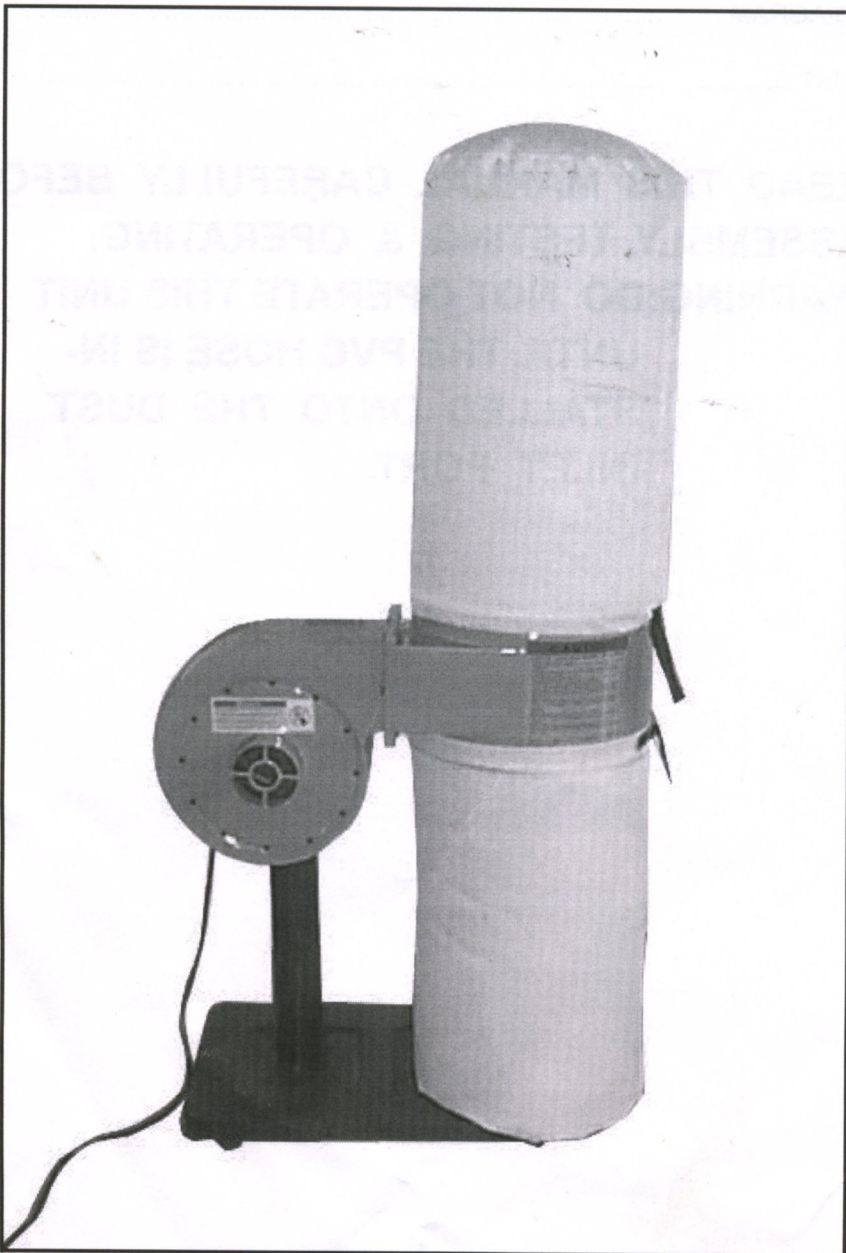

CONTENTS

SAFETY RULES.....	2
GROUNDING.....	3
UNPACKING AND CHECKING CONTENTS.....	4
TO KNOW YOUR DUST COLLECTOR.....	5
ASSEMBLY.....	6-11
OPTIONAL ACCESSORIES.....	12
PARTS DIAGRAM.....	13
PARTS LIST.....	14

**READ THIS MANUAL CAREFULLY BEFORE
ASSEMBLY, TESTING & OPERATING.
WARNING:DO NOT OPERATE THIS UNIT
UNTIL THE PVC HOSE IS IN-
STALLED ONTO THE DUST
INLET PORT.**

SAFETY RULES

- 1. READ AND BECOME FAMILIAR** with the entire operating manual.
- 2. KEEP GUARDS AND COVER** in place and in working order.
- 3. ALWAYS USE SAFETY GLASSES.** Also use face or dust mask if cutting operations is dusty. Everyday eyeglasses only have impact resistant lenses; they are not safety glasses.
- 4. KEEP WORK AREA CLEAN.** Cluttered areas and benches invite accidents.
- 5. DON'T FORCE TOOL.** It will do a better and safer job at the rate for which it was designed.
- 6. AVOID ACCIDENTAL STARTING.** Make sure switch is in "OFF" position before plugging in cord.
- 7. DISCONNECT TOOLS BEFORE SERVICING** and when changing accessories such as blades, bits, cutters.
- 8. DON'T OVERREACH.** Keep your proper footing and balance at all times. For best footing wear rubber soled footwear. Keep floor clear of oil, scrap wood, etc.
- 9. WEAR PROPER APPAREL.** Loose clothing or jewelry may get caught in moving parts. Wear protective hair covering to contain long hair.
- 10. MAKE WORKSHOP KIDPROOF.** Place a padlock on the switch when blade saw is not in use and store the key in a safe location.
- 11. REMOVE ADJUSTING KEYS AND WRENCHES.** Form habit of checking to see that keys and adjusting wrenches are removed from tool before turning it on.
- 12. AVOID DANGEROUS ENVIRONMENT.** Don't use power tools in damp or wet locations. Keep your work area well illuminated *DO NOT USE* in explosive atmosphere (around paint, flammable liquids, etc.)
- 13. KEEP CHILDREN AWAY.** All visitors should be kept a safe distance from work area, especially while operating unit.
- 14. USE THE PROPER TOOL.** Don't force tool or attachment to do a job for which it was not designed.
- 15. MAINTAIN TOOLS IN TOP CONDITION.** Keep tools sharp and clean for best and safest performance. Follow instructions for lubricating and changing accessories.
- 16. SECURE WORK.** Use clamps or a vise to hold work, when practical. It's safer than using your hand and prevents round or irregularly shaped pieces from turning.
- 17. CHECK DAMAGED PARTS.** Before further use of the tool, a guard or other part that is damaged should be checked to assure that it will operate properly and perform its intended function—check for alignment of moving parts, breakage of parts, mounting, any other conditions that may affect its operations. A guard or other part that is damaged should be properly repaired or replaced.
- 18. USE RECOMMENDED ACCESSORIES—**Consult Owner's Manual. Use of improper accessories could be hazardous.
- 19. NEVER STAND ON TOOL.** Injury could occur from a fall.
- 20. NEVER LEAVE TOOL RUNNING AND UNATTENDED.**
- 21. ALWAYS REMOVE CORD PLUG** from electrical outlet when adjusting, changing parts or working on tool.

GROUNDING

1. In the event of a malfunction or breakdown, grounding provides a path of least resistance for electric current to reduce the risk of electric shock. This tool is equipped with an electric cord having an equipment-grounding conductor and a grounding plug. The plug must be plugged into a matching outlet that is properly installed and grounded in accordance with all local codes and ordinances.
2. Do not modify the plug provided it will not fit the outlet, have the proper outlet installed by a qualified electrician.
3. Improper connection of the equipment grounding conductor can result in a risk of electric shock. The conductor with insulation having an outer surface that is green with or without yellow stripe is the equipment-grounding conductor. If repair or replacement of the electric cord or plug is necessary, do not connect the equipment-grounding conductor to a live terminal.
4. Check with a qualified electrician or serviceman if the grounding instructions are not completely understood, or if in doubt as to whether the tool is properly grounded.
5. Use only 3-wire extension cords that have 3-prong grounding plugs and 3-pole receptacles that accept the tool's plug.
6. Repair or replace damaged or worn cord immediately.
7. This tool is intended for use on a circuit that has an outlet that looks like the one illustrated in sketch A. The tool has a grounding plug that looks like the plug illustrated in sketch A. A temporary adapter, which looks like the adapter illustrated in sketches B and C, may be used to connect his plug to a 1-pole receptacle as shown in sketch B if a properly grounded outlet is not available. The temporary adapter should be used only until a properly grounded outlet can be installed by a qualified electrician. The green-colored rigid ear, lug, etc. extending from the adapter must be connected to a permanent ground such as a properly grounded outlet box.
NOTE: The type of electrical plug and receptacle differs from country to country.
Caution: In Canada only the grounding shown in figure (A) is acceptable. The extension cords should be CSA certified S.J.T. type or something better.
Caution: In Australia only the grounding shown in figure (D) is acceptable. The extension cords should be SAA certified.

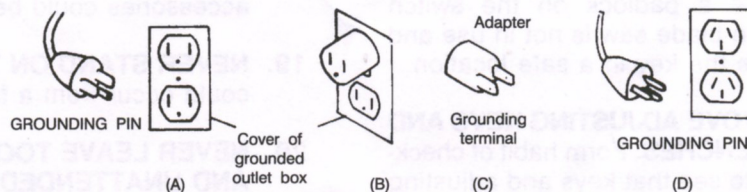

UNPACKING AND CHECKING CONTENTS

Unpack carton, check machine, to see parts listed below:

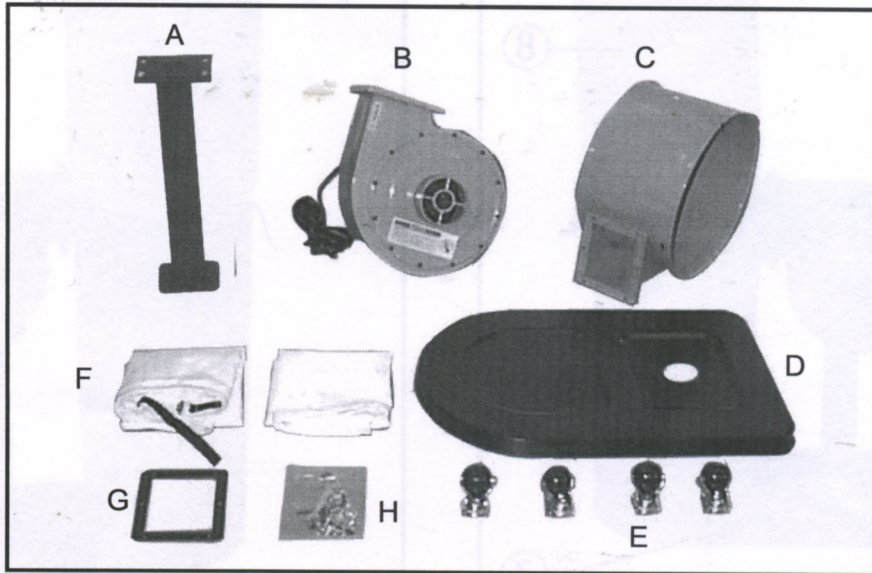

- A. COLLECTOR SUPPORT
- B. COLLECTOR BODY WITH MOTOR
- C. COLLECTOR
- D. BASE PLATE
- E. FOUR CASTERS
- F. TWO BAGS
- G. PACKING
- H. SCREWS AND WASHERS

TO KNOW YOUR DUST COLLECTOR

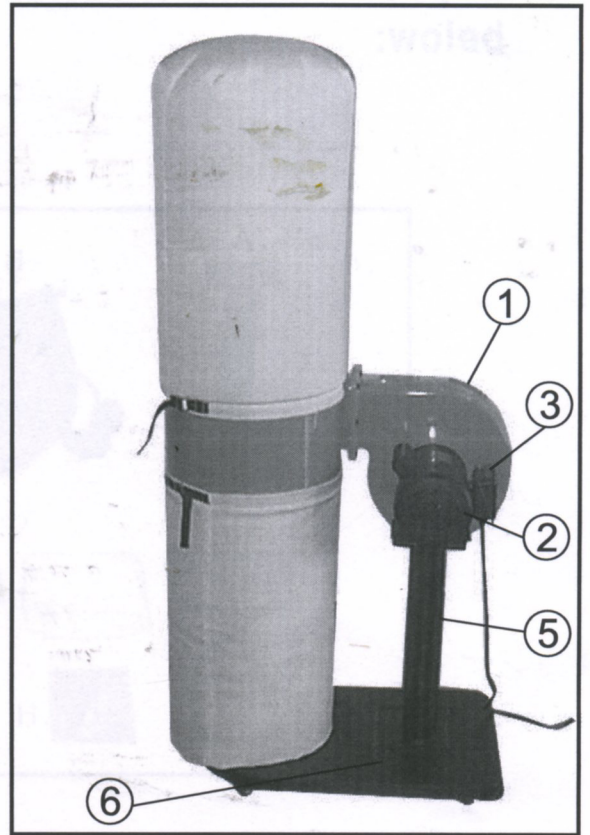
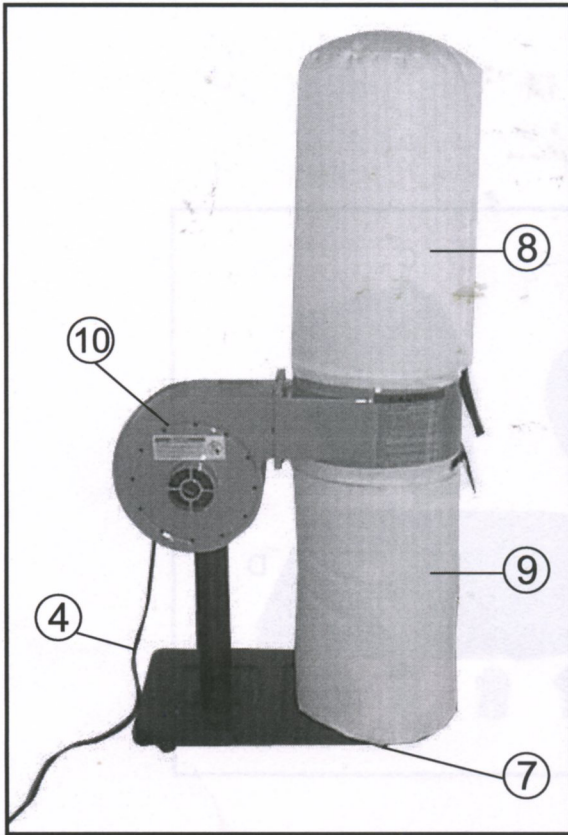

1. COLLECTOR BODY
2. MOTOR
3. ON-OFF SWITCH
4. POWER CORD
5. COLLECTOR SUPPORT
6. BASE PLATE
7. CASTER
8. FILTER BAG
9. COLLECTOR BAG
10. INLET COVER

ASSEMBLY

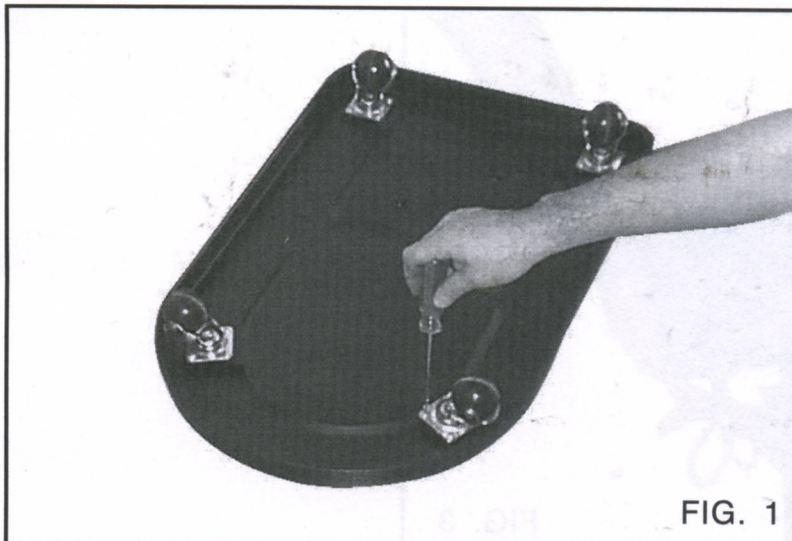

TO ASSEMBLE, PLACE THE BASE PLATE UPSIDE DOWN AND INSTALL THE FOUR CASTERS IN HOLES PROVIDED AND TIGHTEN WITH THE SCREW DRIVER AS SHOWN IN FIG. 1.

FIG. 1

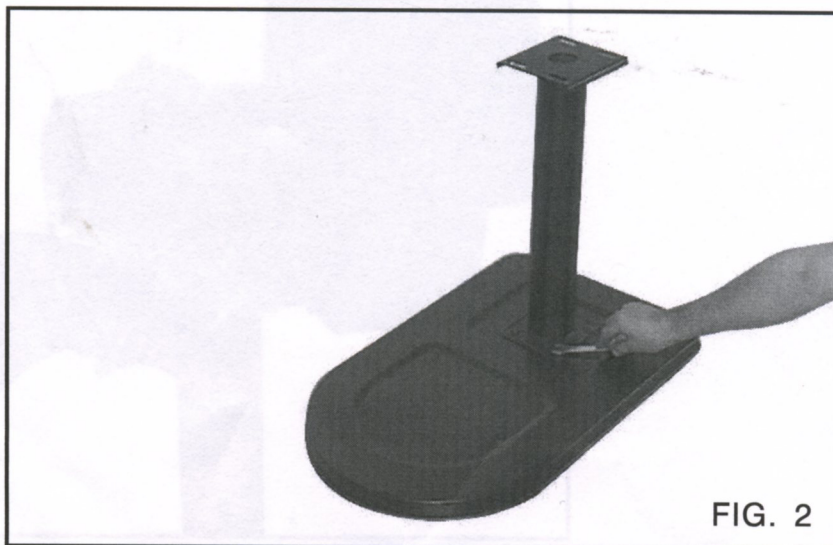

FIG. 2

NEXT, THE BASE PLATE SIDE UP, ATTACH THE COLLECTOR SUPPORT TO THE BASE PLATE USING THE FOUR HOLES PROVIDED AND TIGHTEN WITH THE OPEN END WRENCH AS SHOWN IN FIG. 2.

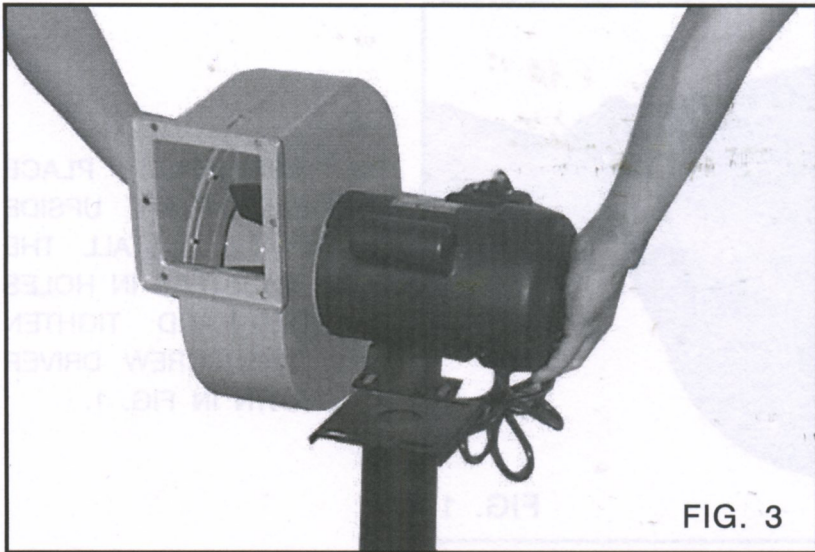

FIG. 3

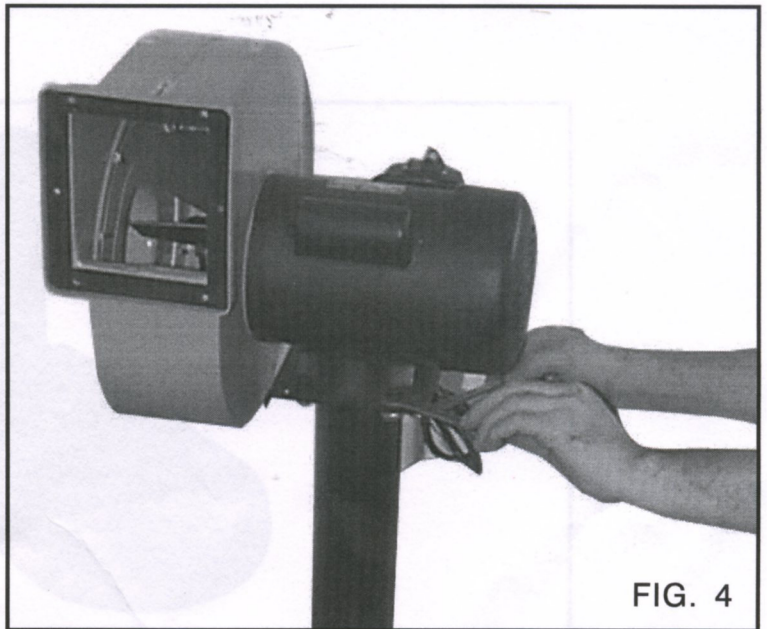

FIG. 4

ATTACH PLACE THE COLLECTOR BODY TO THE MOTOR PLATE AND TIGHTEN THE FOUR BOLTS WASHER, AND NUTS, WITH TWO OPEN END WRENCH AS SHOWN IN FIG. 3 AND FIG. 4.

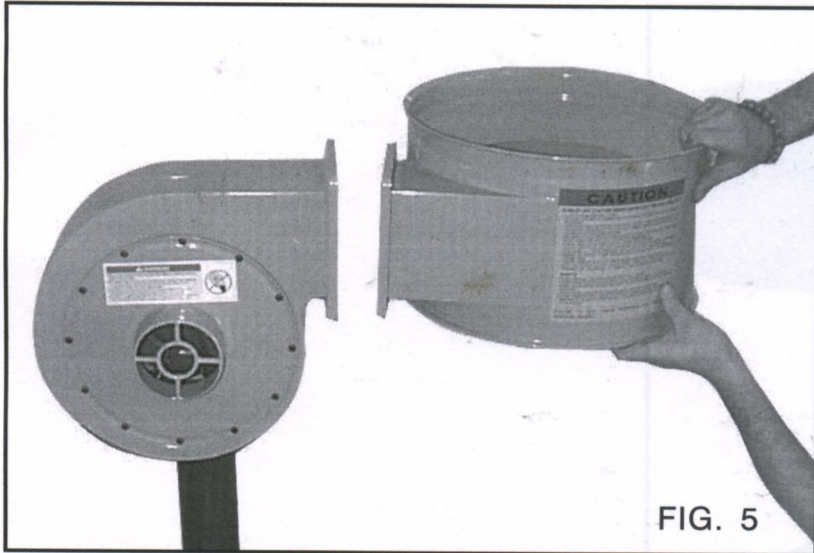

FIG. 5

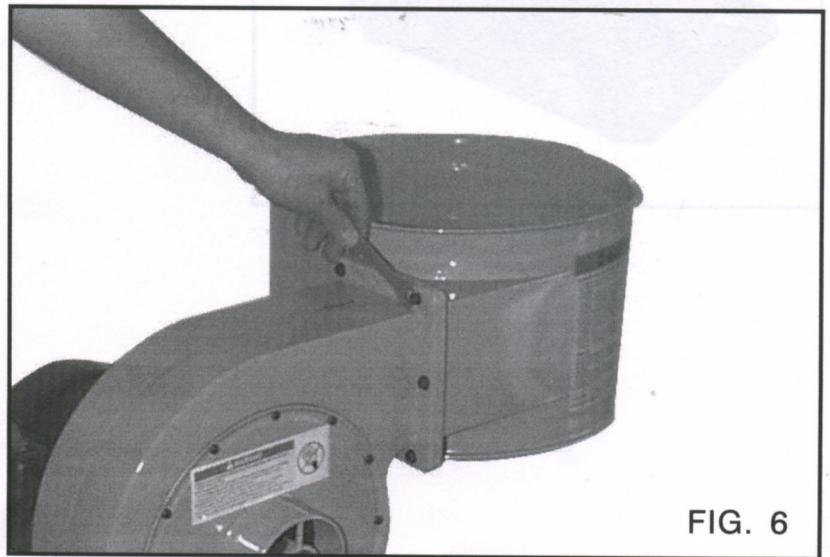

FIG. 6

INSTALL THE COLLECTOR AND PACKING TO THE FAN/
MOTOR ASSY USING SIX FLANGE HEAD SCREWS, PROVIDED. FIG. 5 AND FIG. 6.

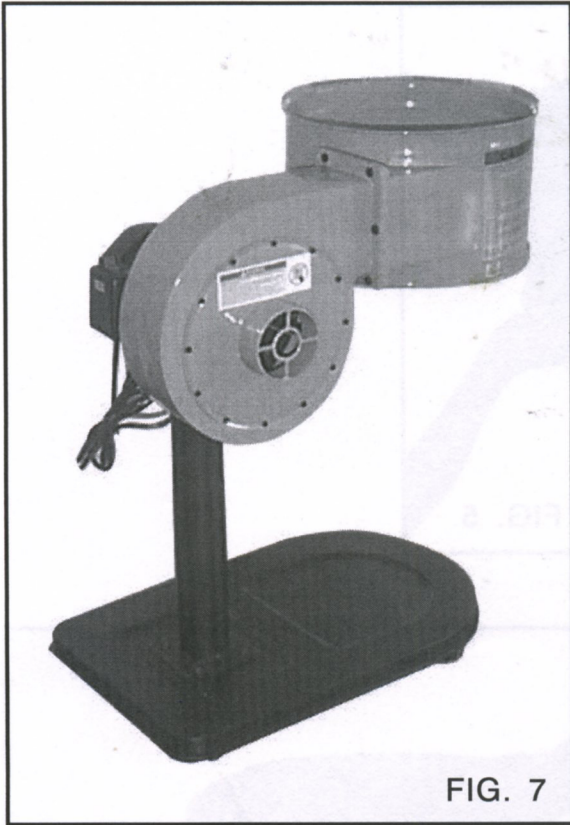

FIG. 7 SHOWS THE DUST COLLECTOR AS IT SHOULD NOW APPEAR.

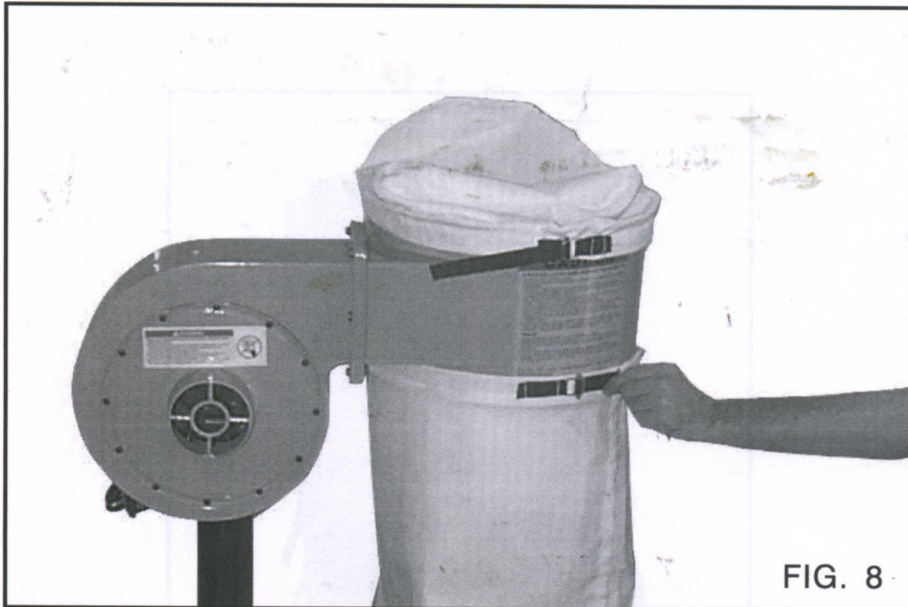

FIG. 8

THE FINAL STEPS TO ASSEMBLING YOUR NEW DUST COLLECTOR IS TO ATTACH THE COLLECTION AND FILTER BAGS. THIS IS DONE BY MERELY PLACING THE BAGS OVER THE OPENING AND SECURING WITH THE BELTS THAT HAVE BEEN SEWN INTO THE BAGS AS SHOWN IN FIG. 8.

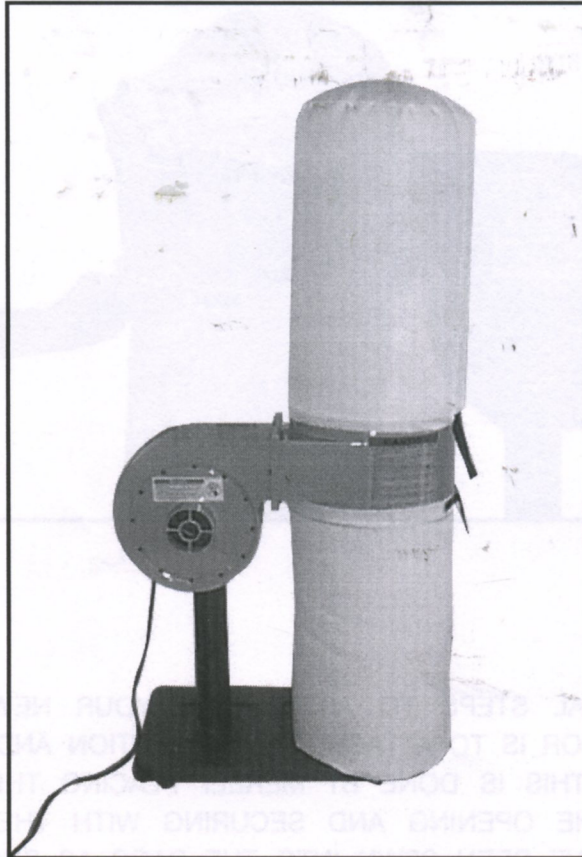

FIG. 9

ATTACH THE DUST COLLECTOR TO A PROPERLY GROUND-
DE CIRCUIT OF CORRECT VOLTAGE, AND THE DUST
COLLECTOR IS NOW READY TO COLLECT ALL DUST AND
POLLUTING ARTICLES.

OPTIONAL ACCESSORIES :

PART NO.	DESCRIPTION.
00-0101	9" ALUMINUM FAN
00-0102	12" ALUMINUM FAN
00-0201	BAG CLAMP FOR CT-80 A/C
00-0202	BAG CLAMP FOR CT-90 A/C
00-0203	BAG CLAMP FOR CT-99 HA/HC
00-0204	BAG CLAMP FOR CT-101/101H/201/201H
00-0205	BAG CLAMP FOR CT-202
00-0206	BAG CLAMP FOR CT-401
00-0301	FLEXIBLE HOSE, 2" IN DIA.
00-0302	FLEXIBLE HOSE, 4" IN DIA.
00-0303	FLEXIBLE HOSE, 5" IN DIA.
00-0304	FLEXIBLE HOSE, 6" IN DIA.
00-0401	REDUCER, 4" TO 2"
00-0501	HOSE CLAMP, 2" OR 6"
00-0601	TRANSARENT COLLECTING BAG
00-0701	AIR FLOW CONTROL CATE, 4" IN DIA.
00-0801	TAPERED CONNECTOR, 4" IN DIA
00-0901	2-HOLE MANIFOLD, 4" OUTLET/5" INLET
00-0902	3-HOLE MANIFOLD, 4" OUTLET/6" INLET
00-0903	4-HOLE MANIFOLD, 4" OUTLET/6" INLET
00-0904	5-HOLE MANIFOLD, 4" OUTLET/9" INLET

PARTS DIAGRAM

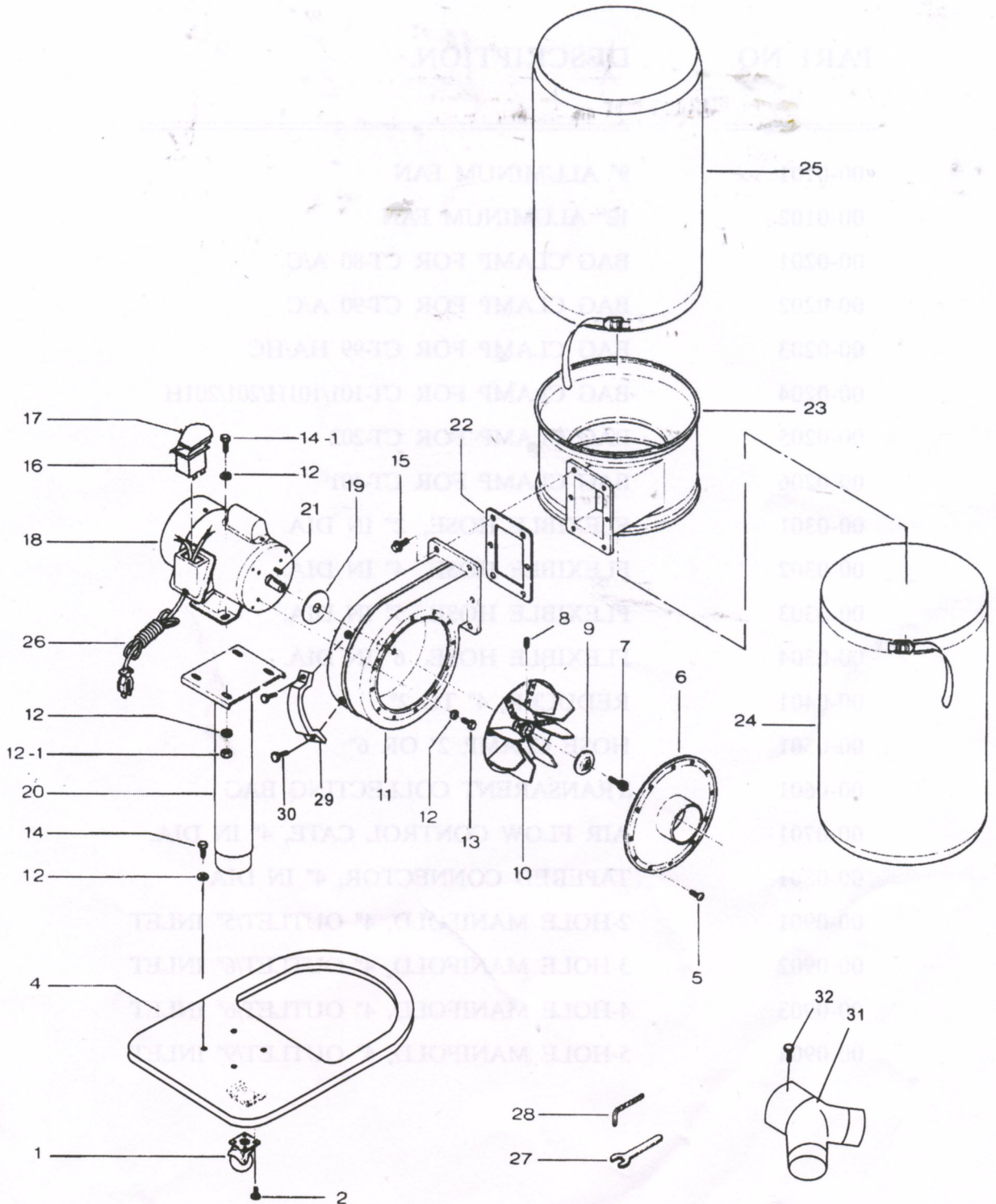

PARTS LIST

PART NO	DESCRIPTION	SPECIFICATION	QUANTITY
1	CASTER	2"	4
2	PAN. HD. SCREW	3/16" x 38"	16
4	BASE PLATE		1
5	PAN HD. SCREW	3/16" x 3/8"	12
6	INLET COVER		1
7	SCREW HEX. SOC.HD	M6 x 20L	1
8	SET SCREW SOC.HD.	5/16" x 5/16"	1
9	WASHER		1
10	TURBO FAN		1
11	COLLECTOR BODY		1
12	WASHER	5/16"	4
12-1	NUT	5/16"	4
13	SCREW HEX. HD.	1/4" x 1/2"	4
14	SCREW HEX. HD.	5/16" x 3/4"	4
14-1	SCREW HEX. HD.	5/16" x 3/4"	4
15	SCREW HEX. FIG. HD.	1/4" x 1/2"	6
16	SWITCH		1
17	KEY-SWITCH		1
18	MOTOR		1
19	PACKING		1
20	COLUMN & MOTOR PLATE		1
21	KEY	5 x 5 x 30mm	1
22	PACKING		
23	COLLECTOR		1
24	COLLECTOR BAG		1
25	FILTER BAG		1
26	POWER CORD		1
27	OPEN END WRENCH	10 x 12mm	1
28	HEX. WRENCH	5mm	1
29	HANDLE (OPTIONAL)		1
30	HEX. SCREW (OPTIONAL)	1/4" x 1/2"	2
31	TWO HOLE INLET (OPTIONAL)	5" x 4"	1
32	SCREW PAN. HD. (OPTIONAL)	3/16" x 3/8"	1

PARTS LIST

18	3/16" x 3/8"	PAN HD SCREW
19		
20	3/16" x 3/8"	PAN HD SCREW
21		W/ FIKOVER
22	M 1.2x1.0	SCREW HEX 800HD
23	3/16" x 3/8"	NET SCREW 800 HD
24		WASHER
25		TURBO FAN
26		COLLECTOR BODY
27	3/16"	WASHER
28	3/16"	NUT
29	1/4" x 1/2"	SCREW HEX HD
30	3/16" x 3/4"	SCREW HEX HD
31	3/16" x 3/4"	SCREW HEX HD
32	1/4" x 1/2"	SCREW HEX HD
33		SWITCH
34		KEY SWITCH
35		FEEDER
36		PACKING
37		ALUMIN & MOTOR PLATE
38	5 x 5 x 30mm	KEY
39		PACKING
40		COLLECTOR
41		COLLECTOR BAG
42		FILTER BAG
43		POWER CORD
44	10 x 12mm	OPEN END WRENCH
45	5mm	HEX WRENCH
46		HANDLE (OPTIONAL)
47	1/4" x 1/2"	HEX SCREW (OPTIONAL)
48	5/16"	TWO HOLE INLET (OPTIONAL)
49	3/16" x 3/8"	SCREW PAN HD (OBS)